

Les sept pièces formant le cube Soma :

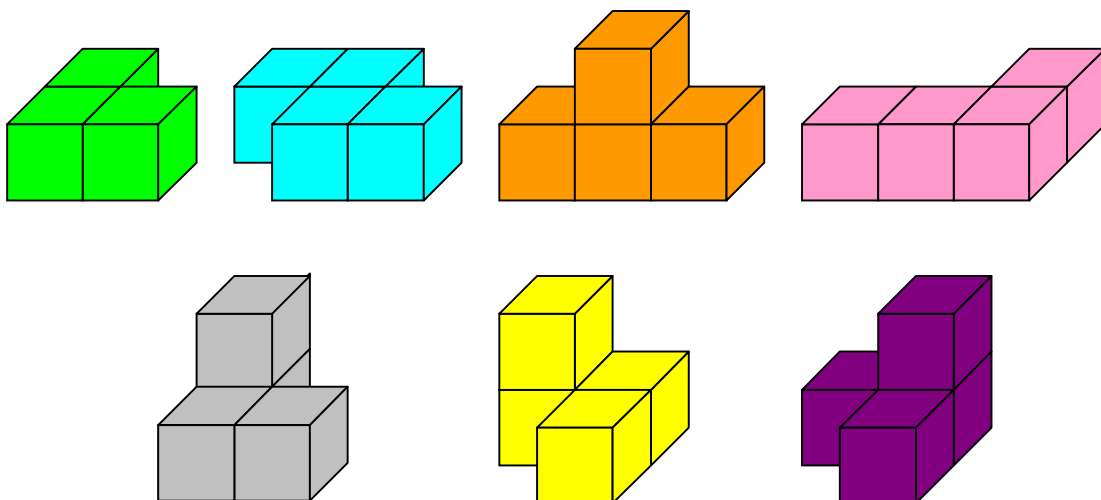

Dans la brochure Jeux 5, ces pièces sont le support d'activités pour la classe. Claude Pagano s'est lancé dans la recherche de solides pouvant être réalisés avec elles.

Des solides à construire avec les sept pièces :

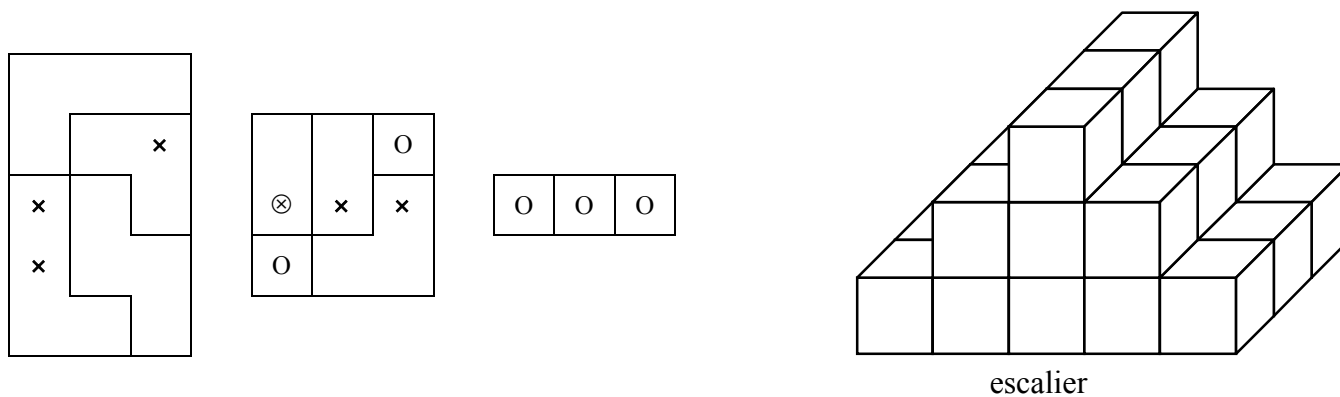

Il présentait ses découvertes en utilisant le codage suivant : « O » signifie que la pièce se prolonge vers le bas, « x » signifie que la pièce se prolonge vers le haut, « ⊗ » signifie que la pièce se prolonge vers le haut et vers le bas.

Pour faciliter l'utilisation de son codage avec de jeunes élèves, est rajouté dans ce document des dessins en perspective des solides à construire.

Des solides à reconstituer avec les sept pièces du cube Soma (1)

Le codage « O » signifie que la pièce se prolonge vers le bas, le codage « x » signifie que la pièce se prolonge vers le haut, le codage « ⊗ » signifie que la pièce se prolonge vers le haut et vers le bas.

La couche supérieure de l'assemblage de cubes formant le solide se trouve dans la partie droite du codage de la solution proposée par Claude Pagano (la couche inférieure se trouve dans la partie gauche). La solution codée et le dessin en perspective représentent parfois deux positions différentes du solide.

Les noms des solides sont ceux qui figurent sur les documents confiés par Claude Pagano.

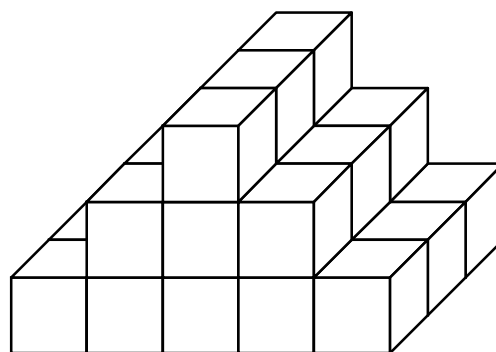
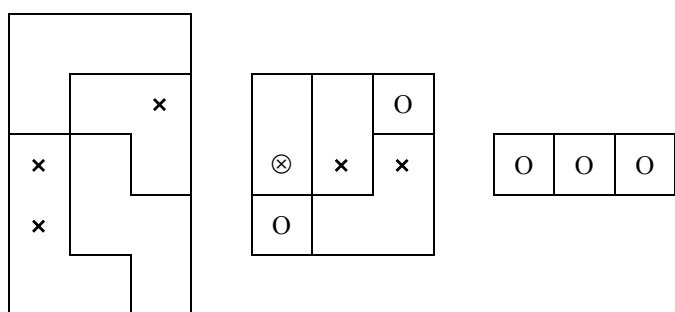

escalier

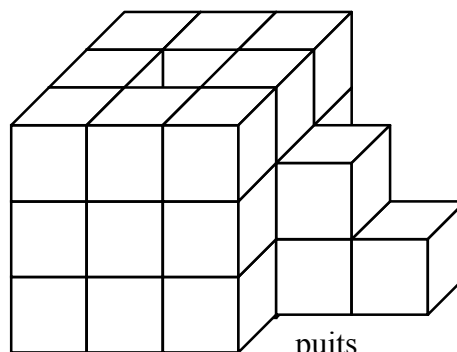
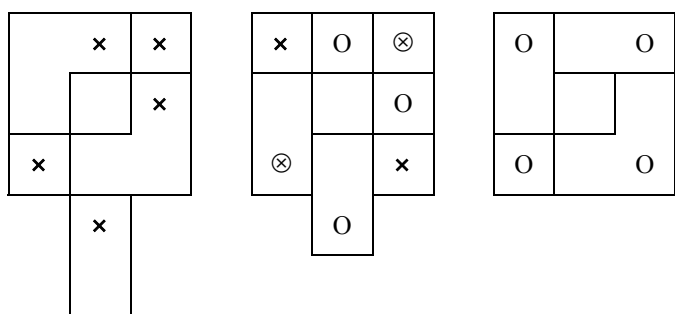

puits

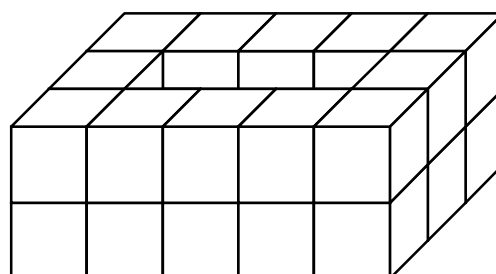
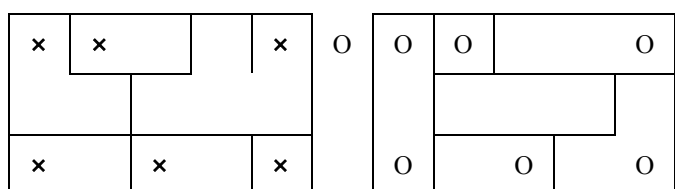

baignoire

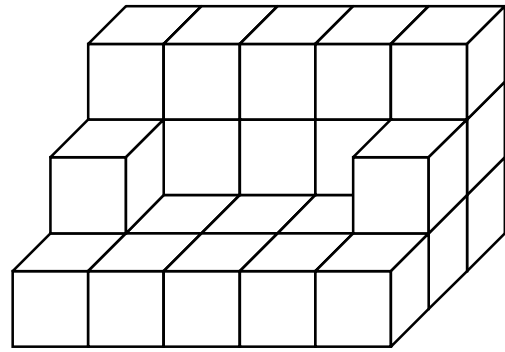
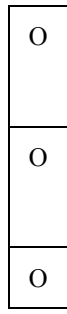
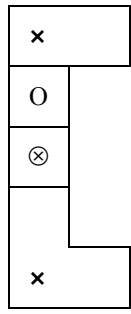
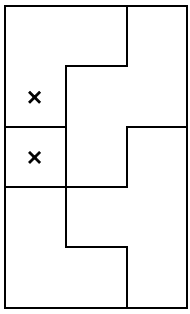

fauteuil

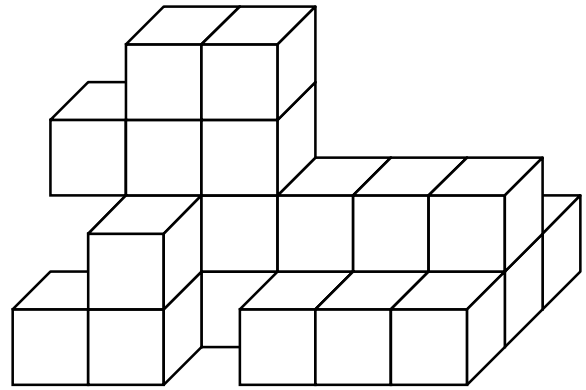
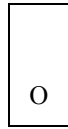
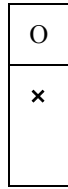
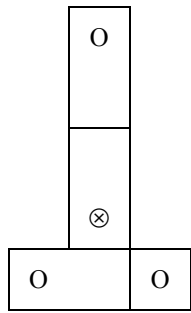
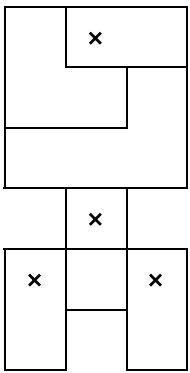

chien

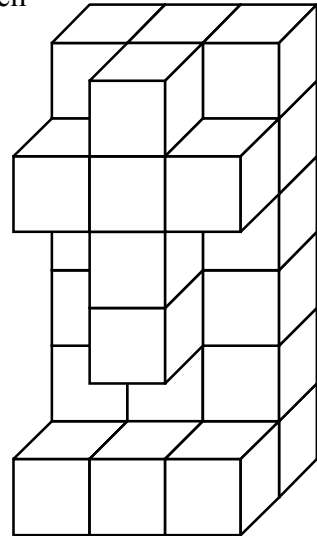
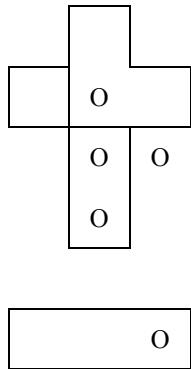
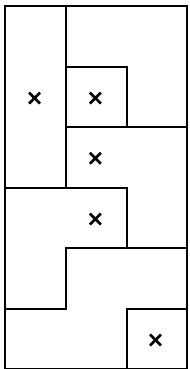

calvaire

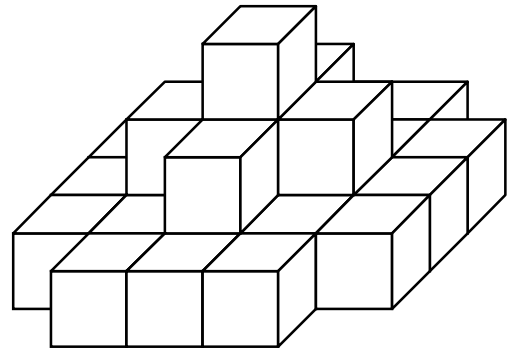
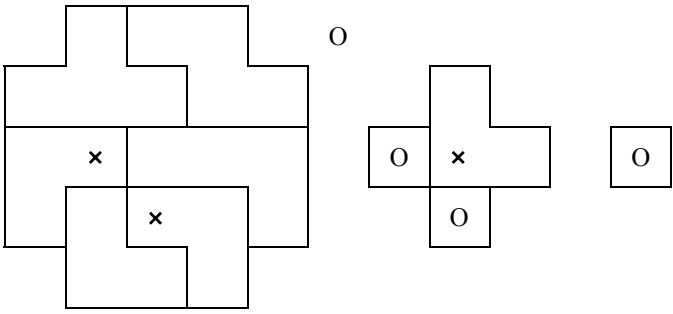

pyramide

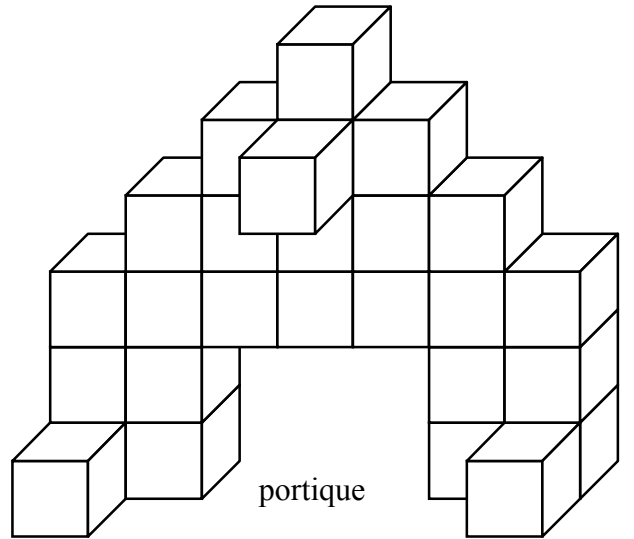
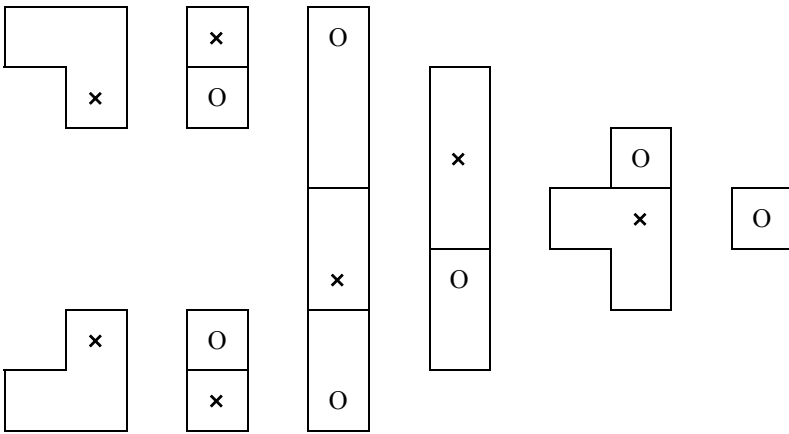

portique

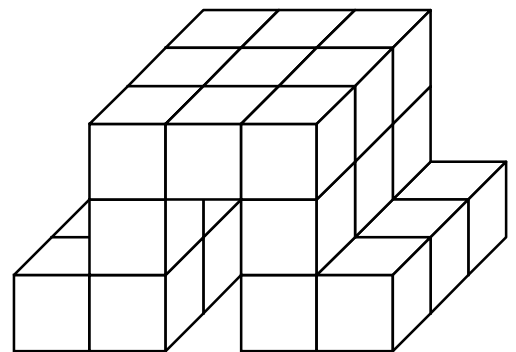
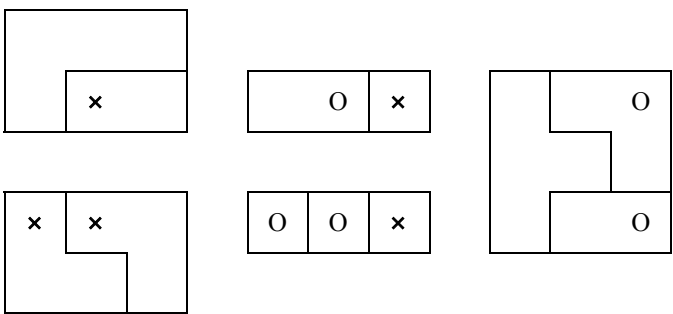

tunnel

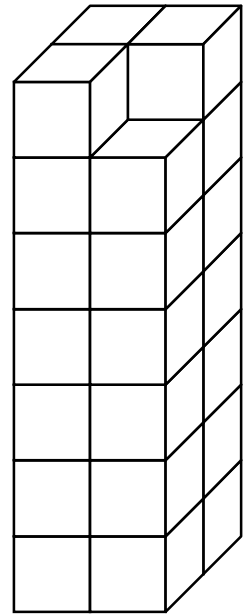
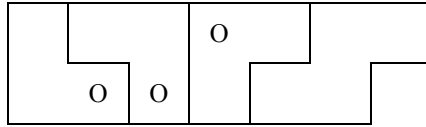
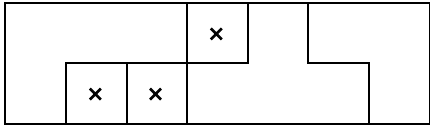

tour

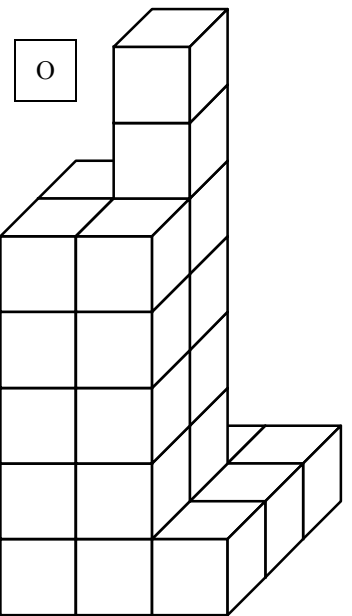
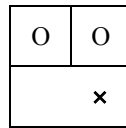
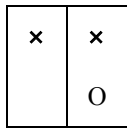
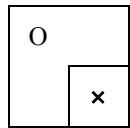
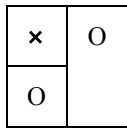
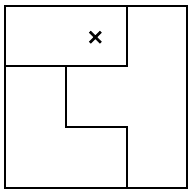

gratte ciel

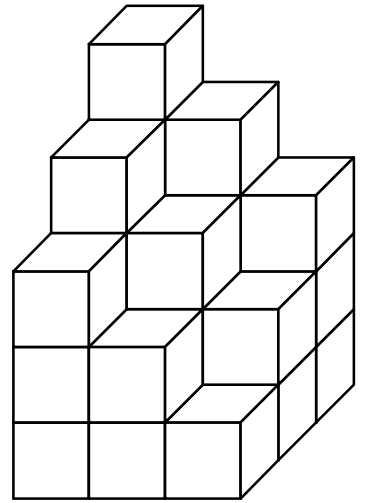
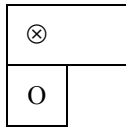
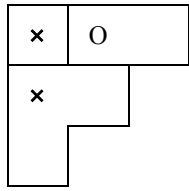
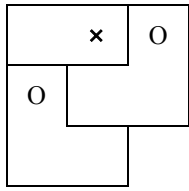
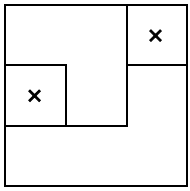

crystal

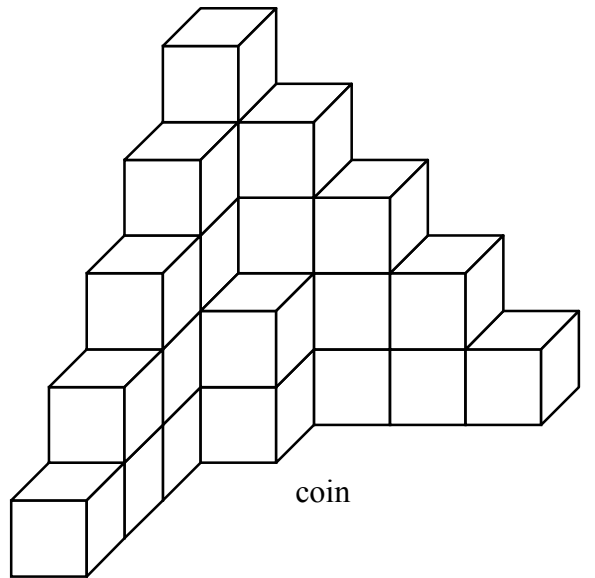
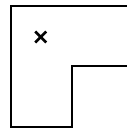
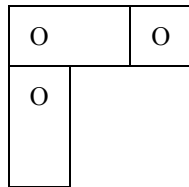
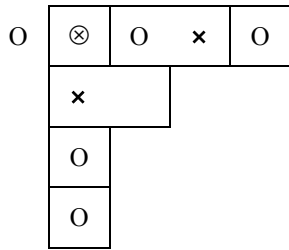
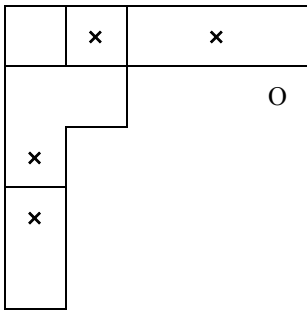

coin

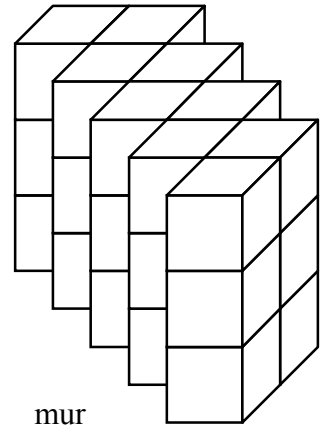
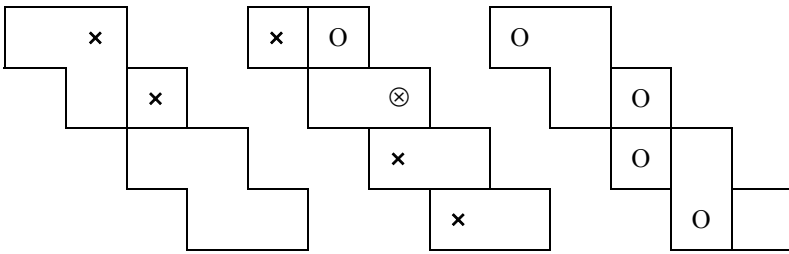
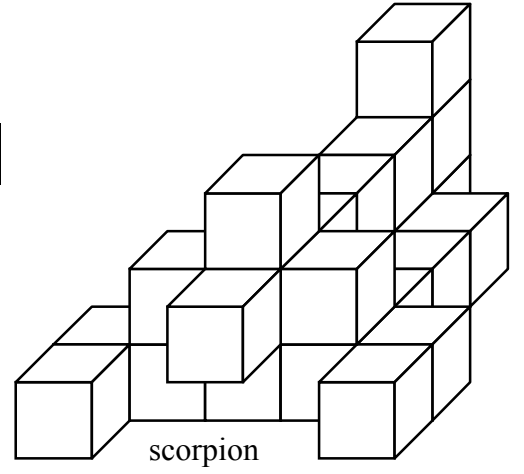
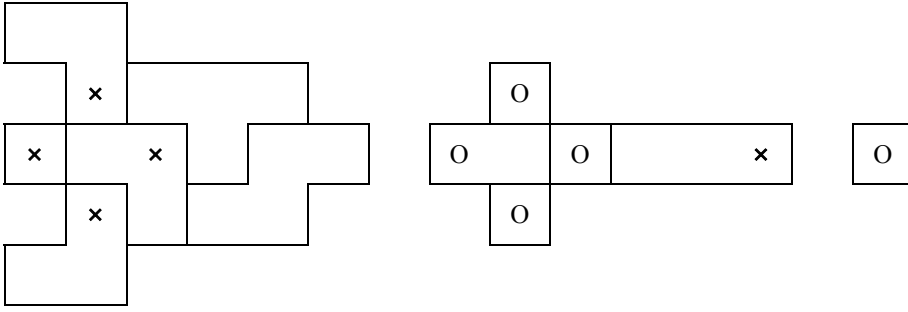

Des solides à reconstituer avec les sept pièces du cube Soma (2)

Le codage « O » signifie que la pièce se prolonge vers le bas, le codage « x » signifie que la pièce se prolonge vers le haut, le codage « ⊗ » signifie que la pièce se prolonge vers le haut et vers le bas.

La couche supérieure de l'assemblage de cubes formant le solide se trouve dans la partie droite du codage de la solution proposée par Claude Pagano (la couche inférieure se trouve dans la partie gauche). La solution codée et le dessin en perspective représentent parfois deux positions différentes du solide.

Les noms des solides sont ceux qui figurent sur les documents confiés par Claude Pagano.

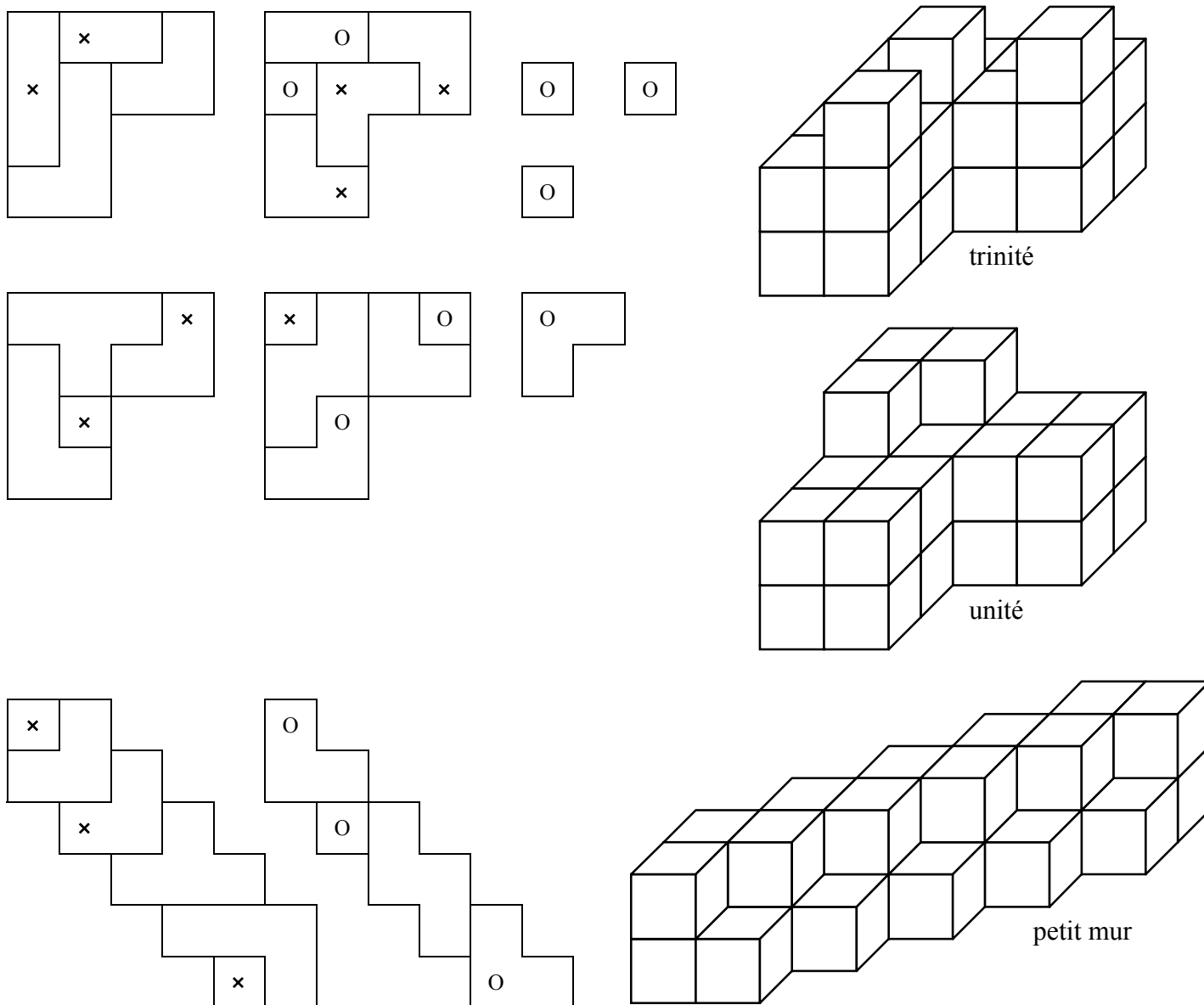

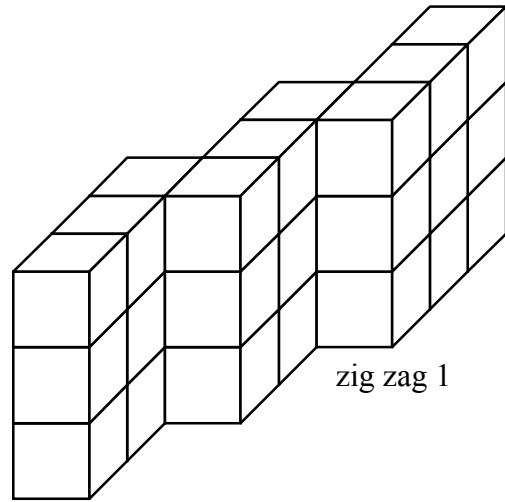
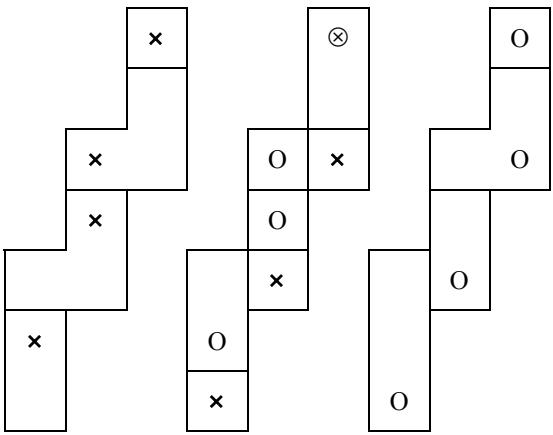
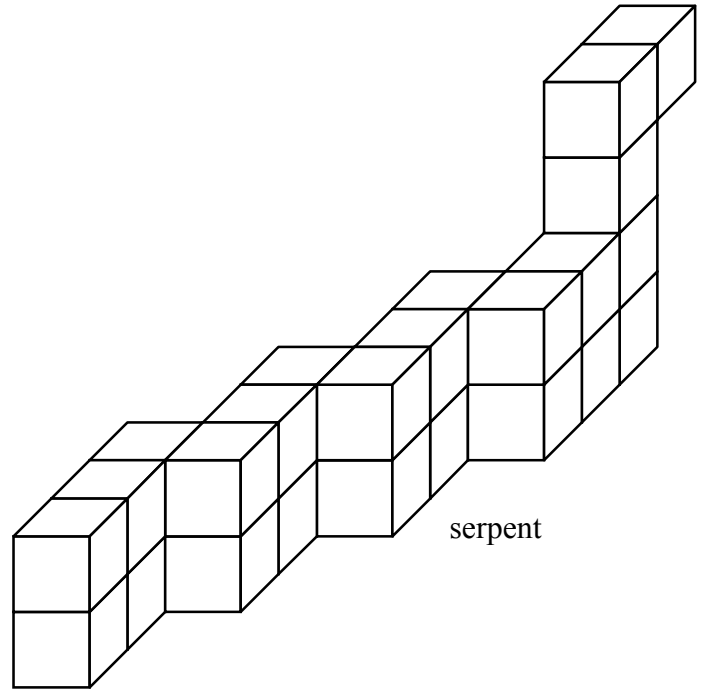
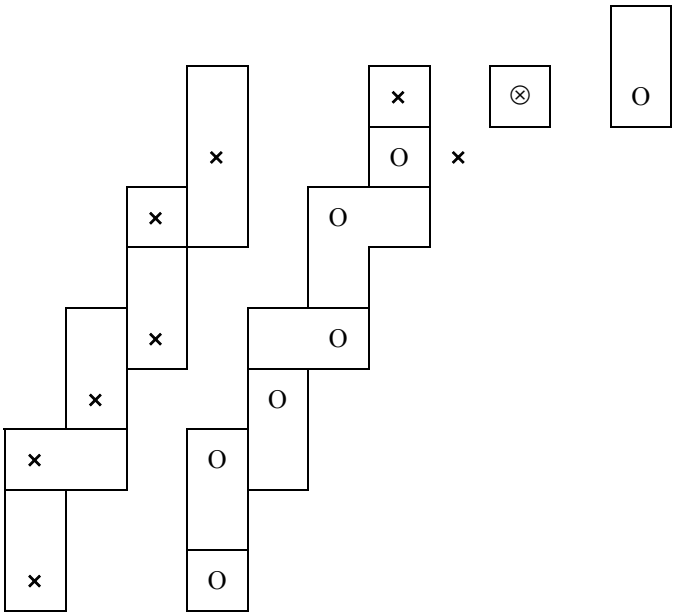

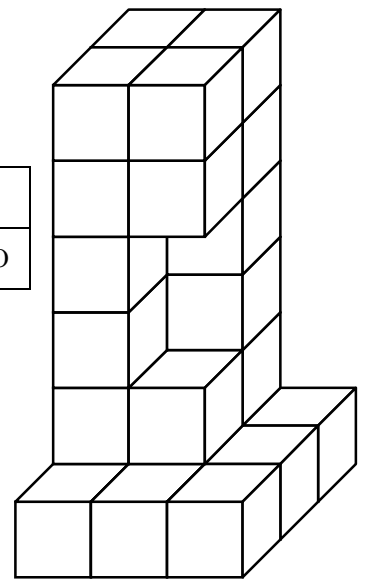
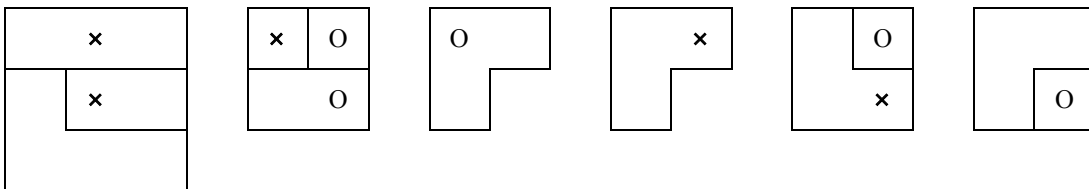
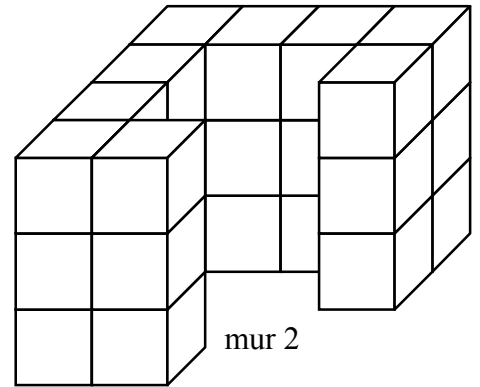
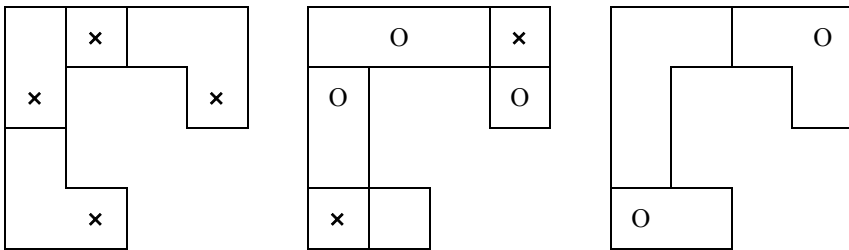
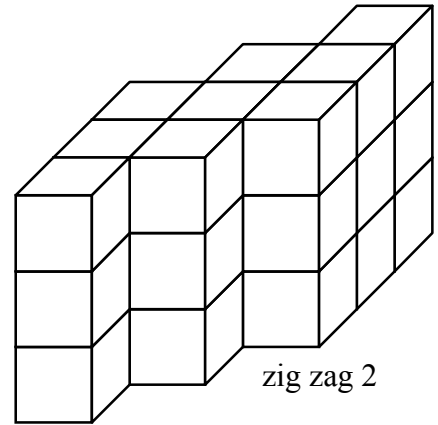
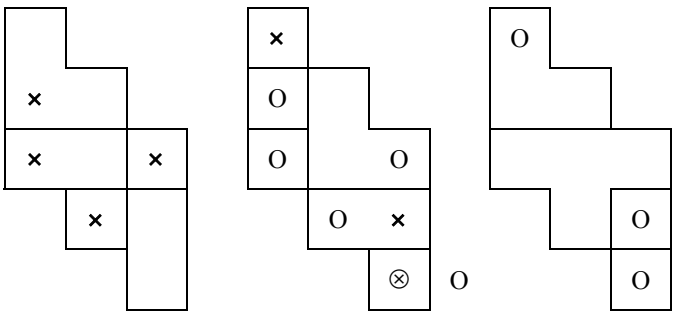

niche basse

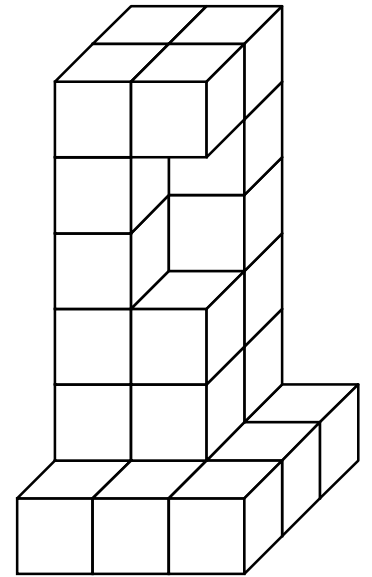
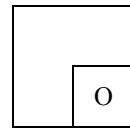
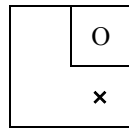
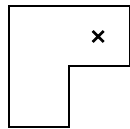
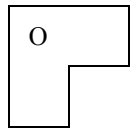
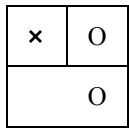
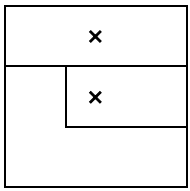

niche haute

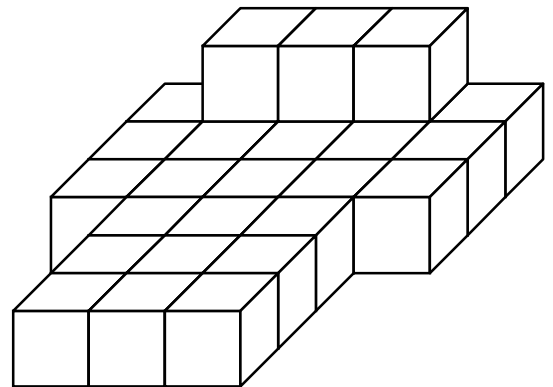
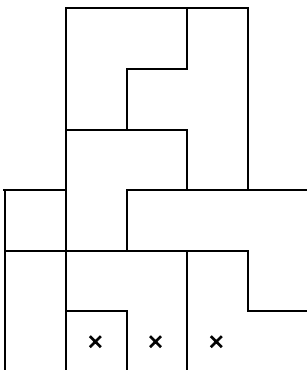
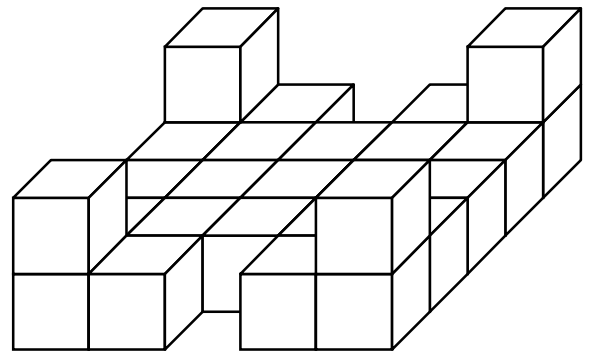
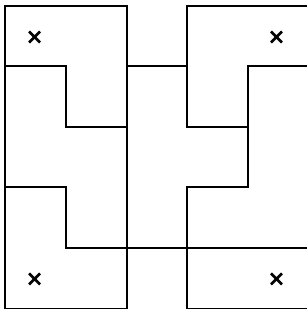

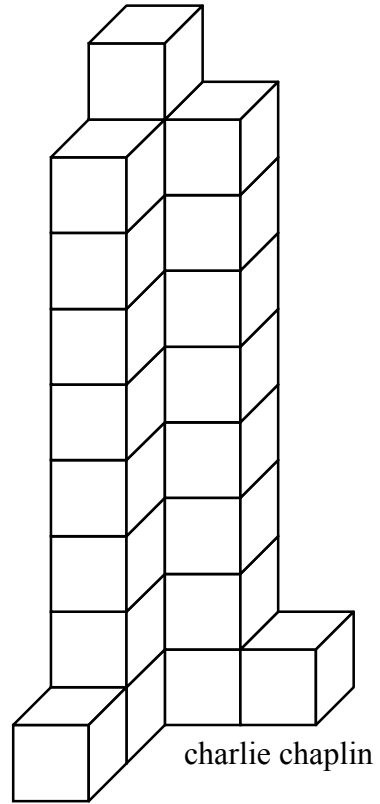
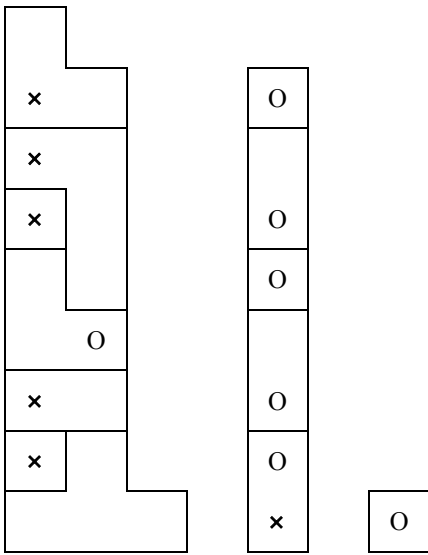
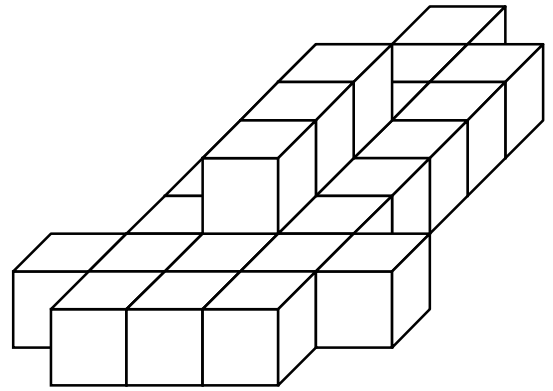
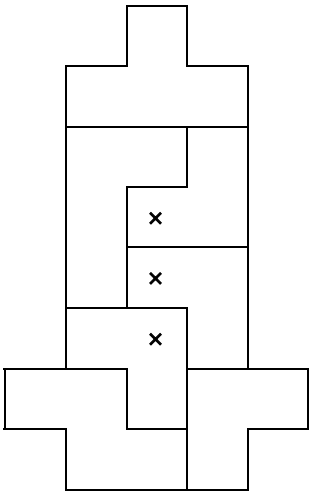

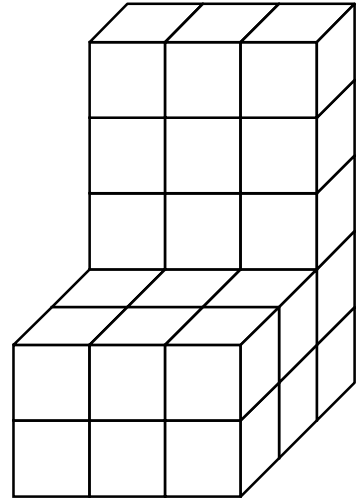
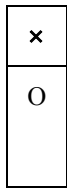
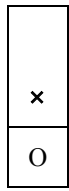
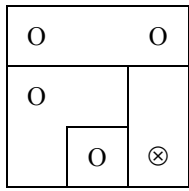
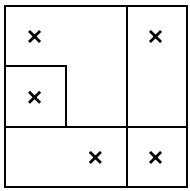

chaise

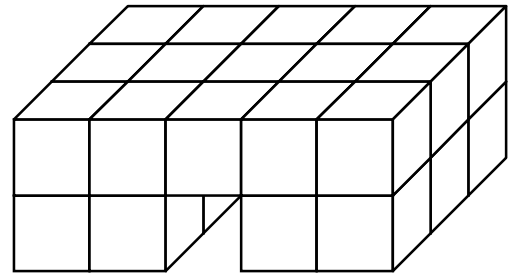
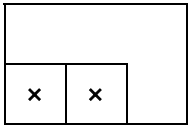
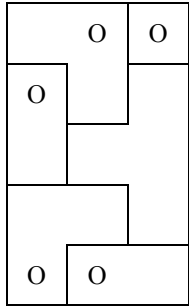
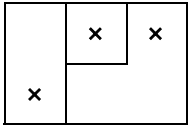

petit pont

Des solides à reconstituer avec les sept pièces du cube Soma (3)

Le codage « O » signifie que la pièce se prolonge vers le bas, le codage « x » signifie que la pièce se prolonge vers le haut, le codage « ⊗ » signifie que la pièce se prolonge vers le haut et vers le bas.

La couche supérieure de l'assemblage de cubes formant le solide se trouve dans la partie droite du codage de la solution proposée par Claude Pagano (la couche inférieure se trouve dans la partie gauche). La solution codée et le dessin en perspective représentent parfois deux positions différentes du solide.

Les noms des solides sont ceux qui figurent sur les documents confiés par Claude Pagano.

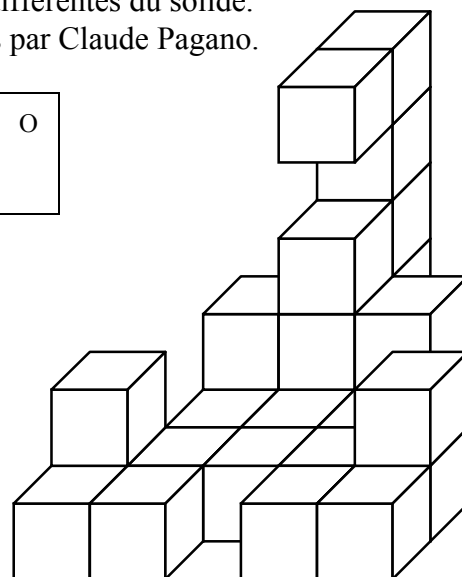
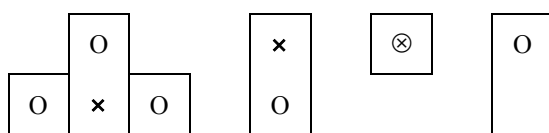
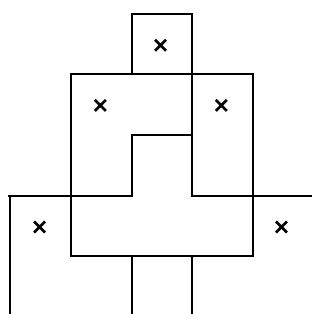

tombe

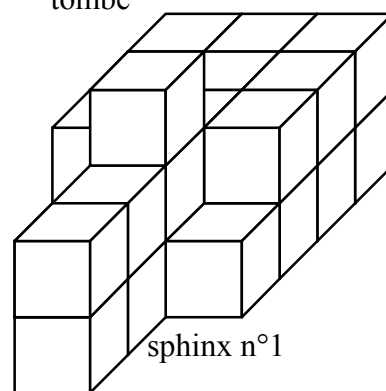
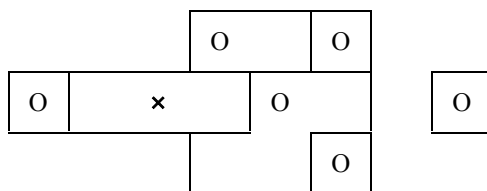
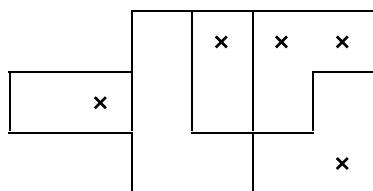

sphinx n°1

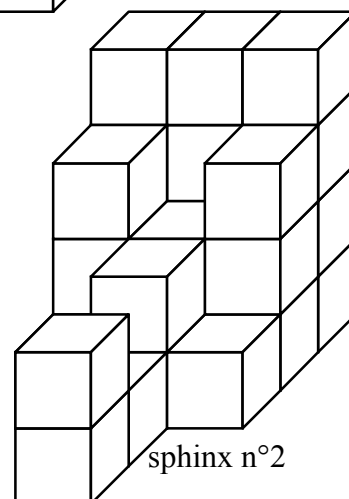
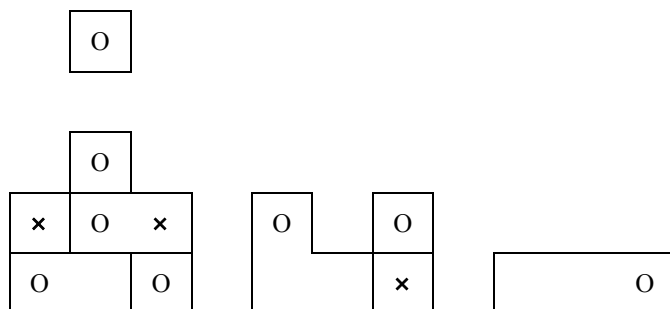
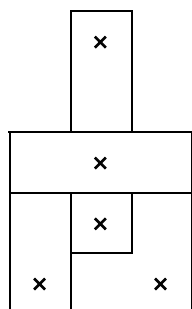

sphinx n°2

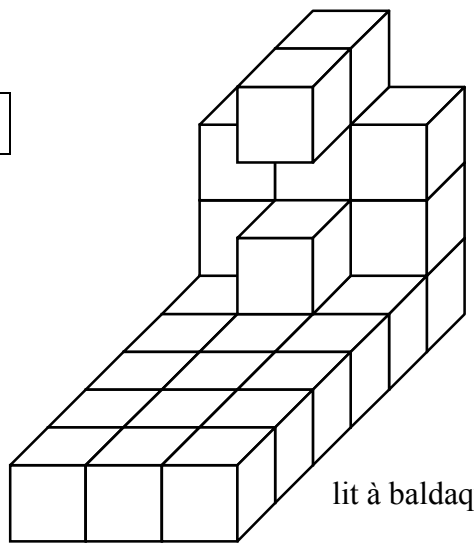
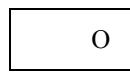
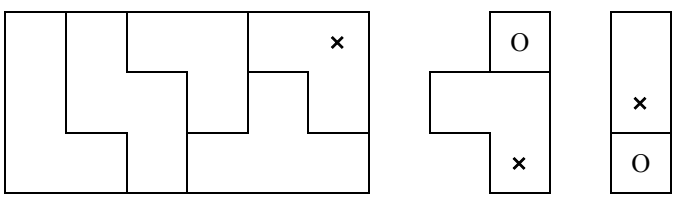
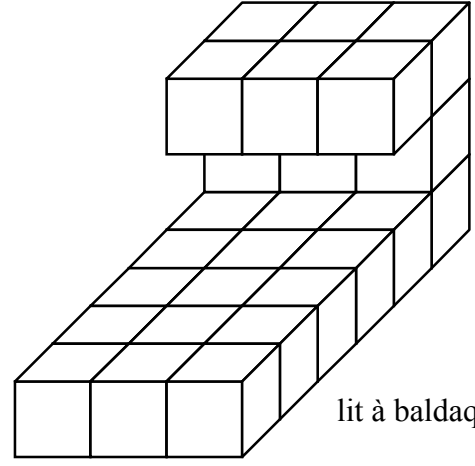
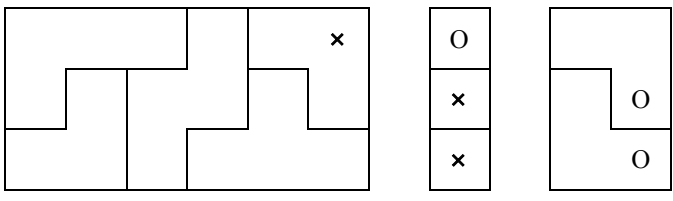
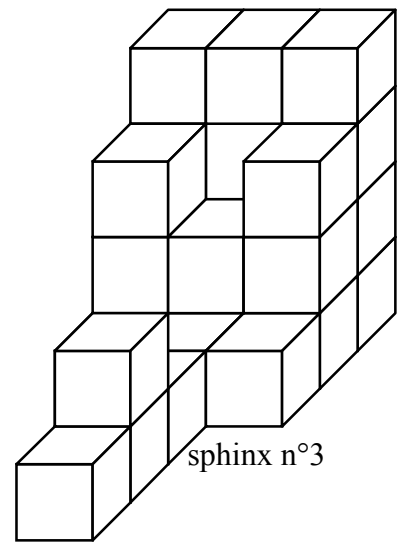
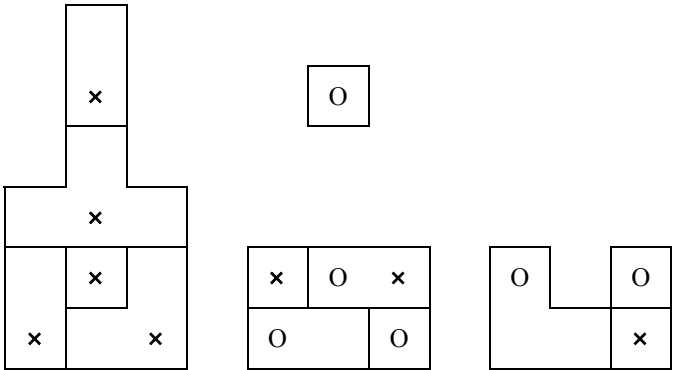

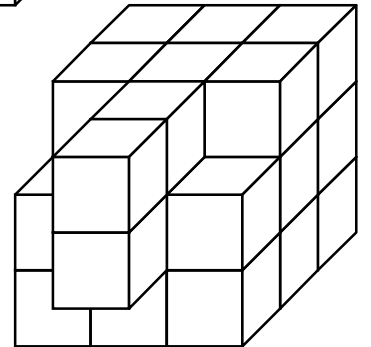
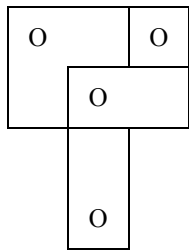
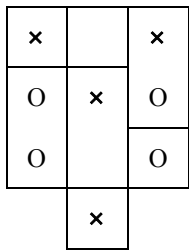
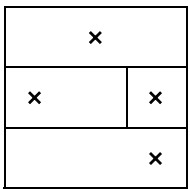
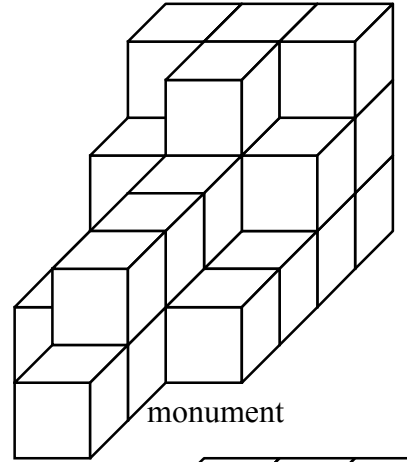
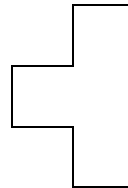
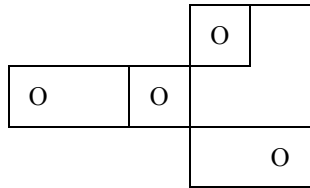
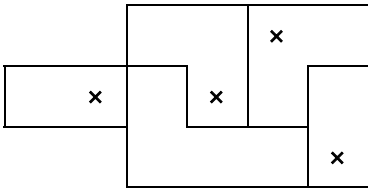
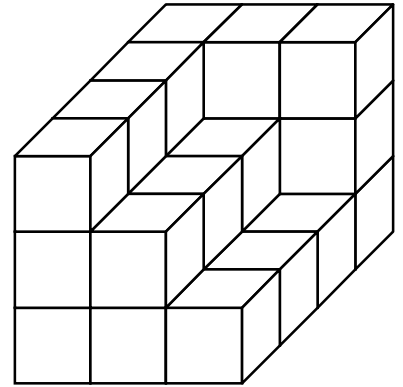
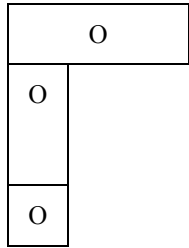
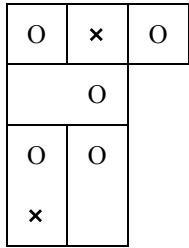
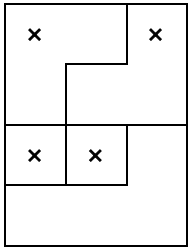
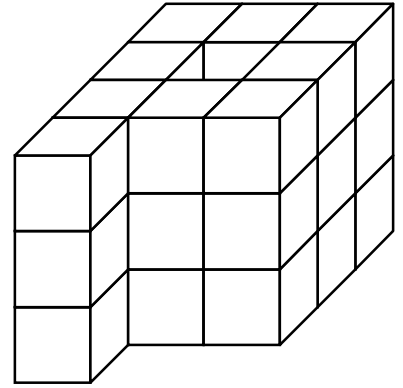
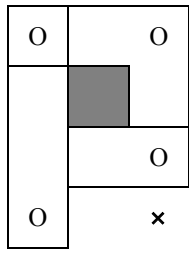
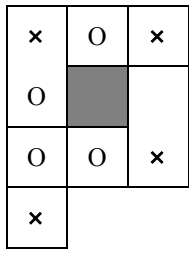
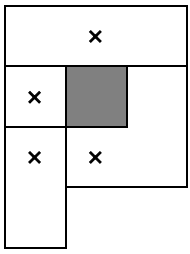

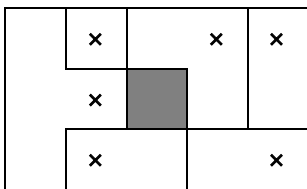
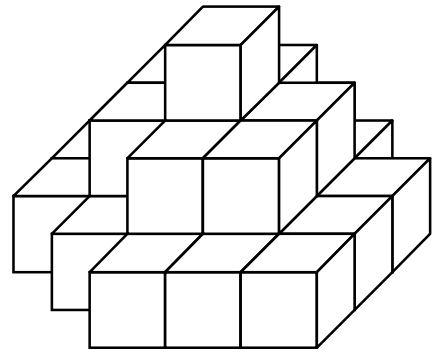
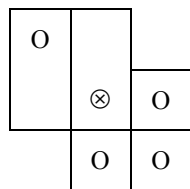
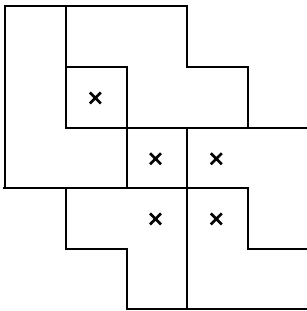
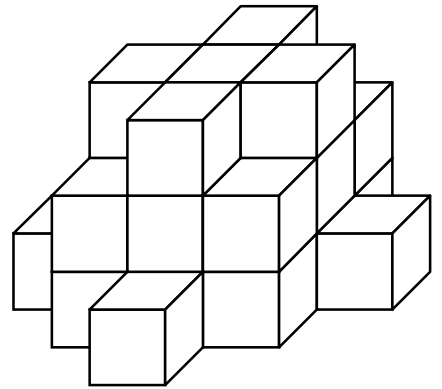
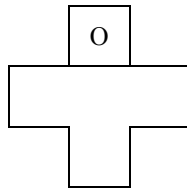
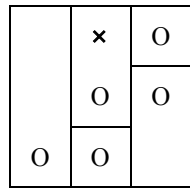
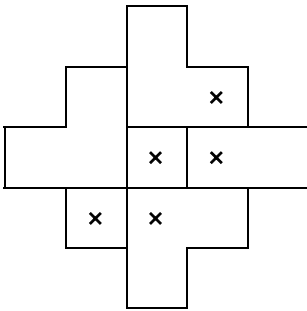
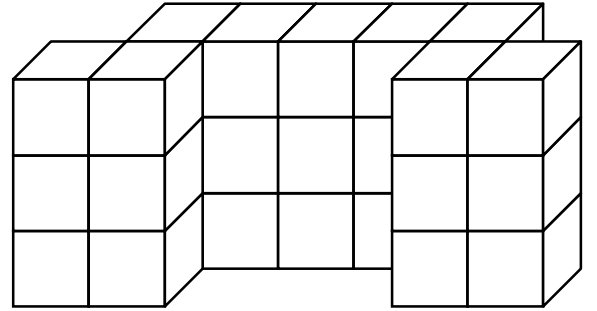
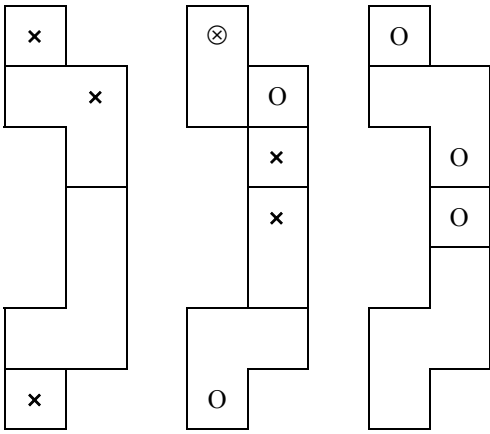

x

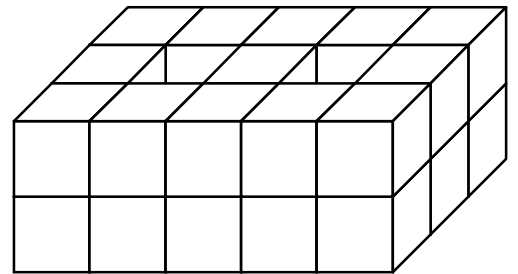
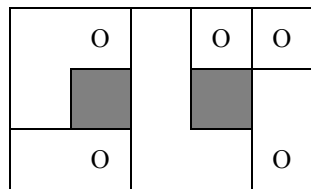

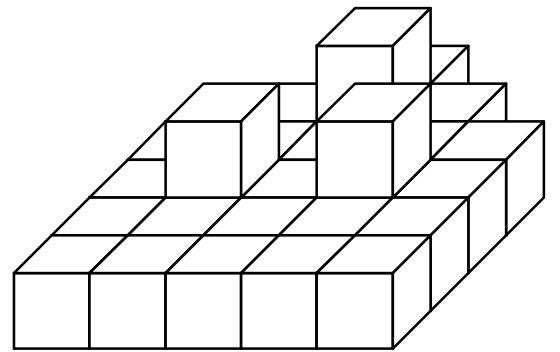
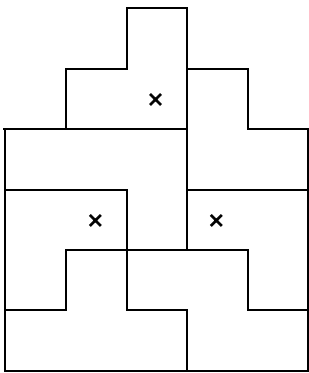
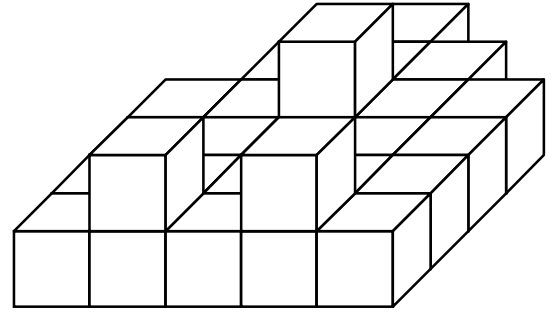
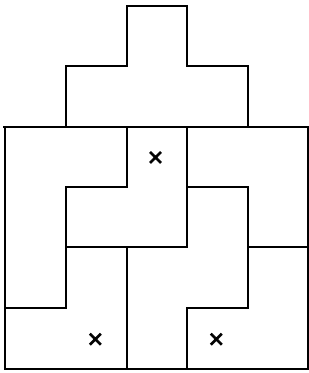

Des solides à reconstituer avec les sept pièces du cube Soma (4)

Le codage « O » signifie que la pièce se prolonge vers le bas, le codage « x » signifie que la pièce se prolonge vers le haut, le codage « ⊗ » signifie que la pièce se prolonge vers le haut et vers le bas.

La couche supérieure de l'assemblage de cubes formant le solide se trouve dans la partie droite du codage de la solution proposée par Claude Pagano (la couche inférieure se trouve dans la partie gauche). La solution codée et le dessin en perspective représentent parfois deux positions différentes du solide.

Les noms des solides sont ceux qui figurent sur les documents confiés par Claude Pagano.

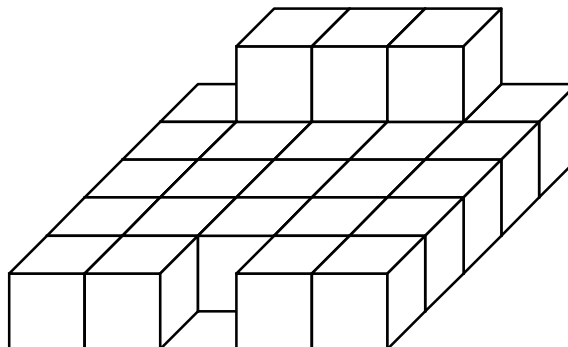
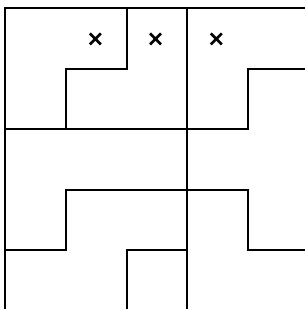
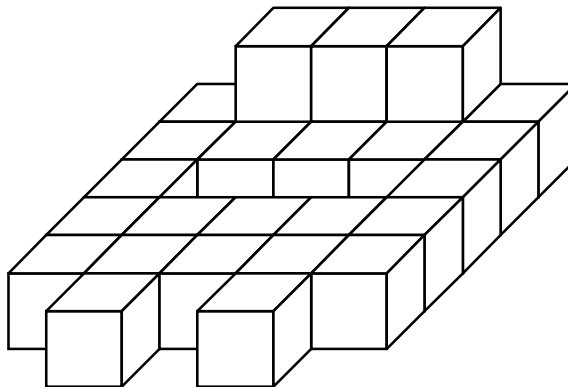
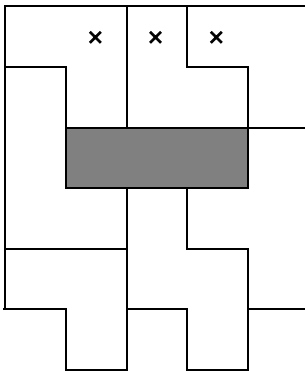
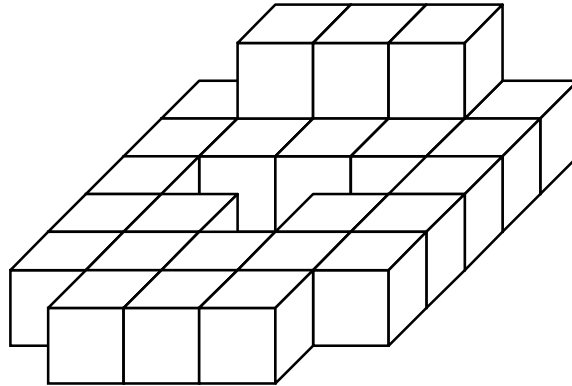
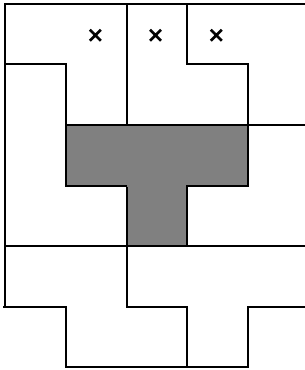

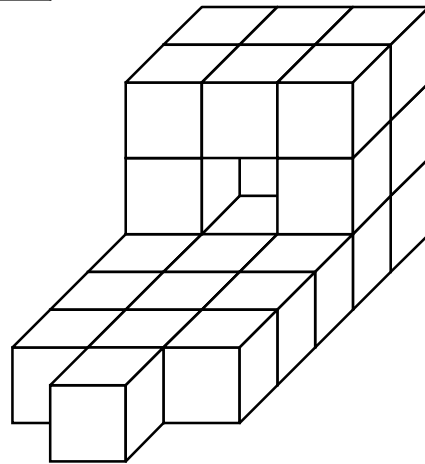
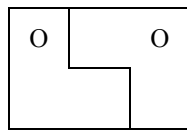
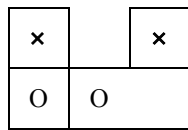
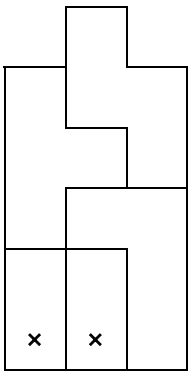
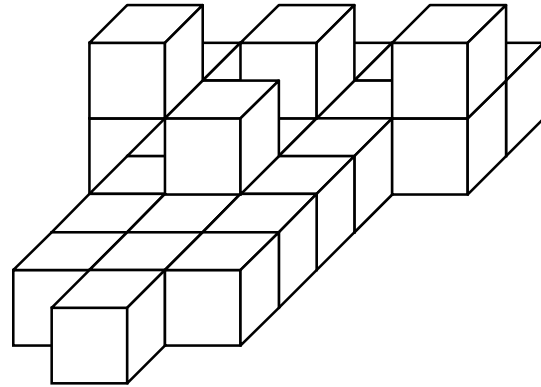
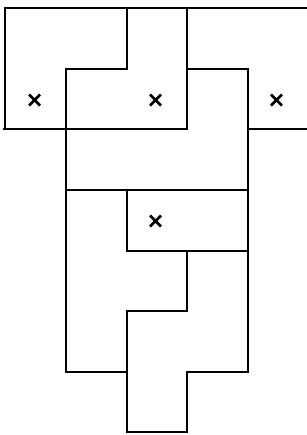
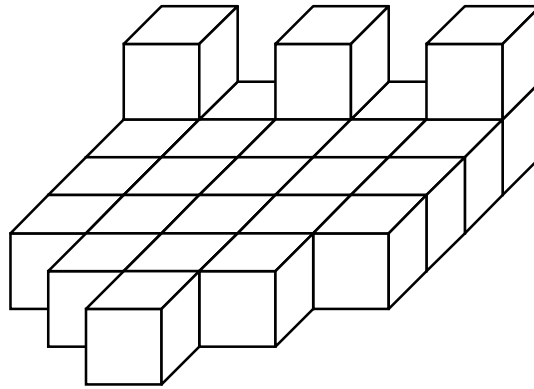
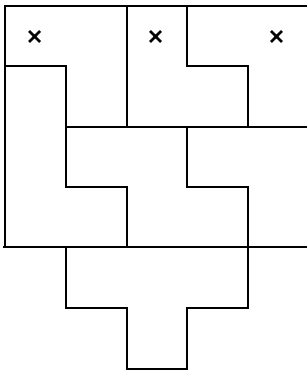

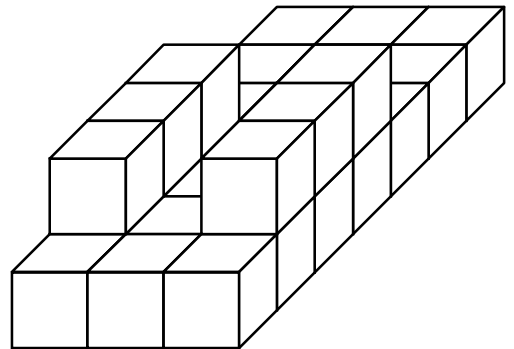
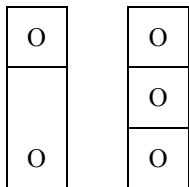
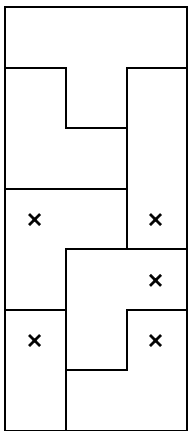
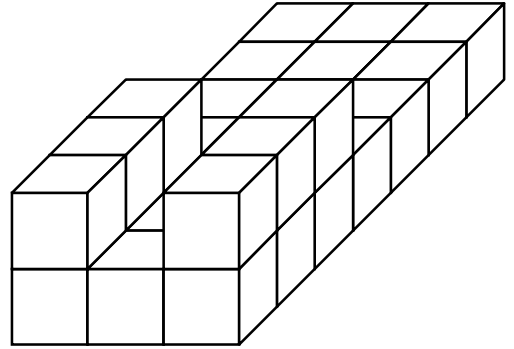
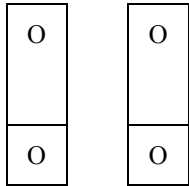
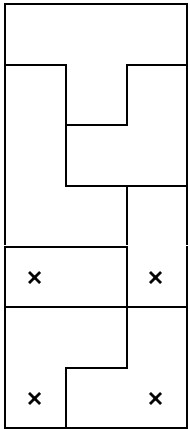
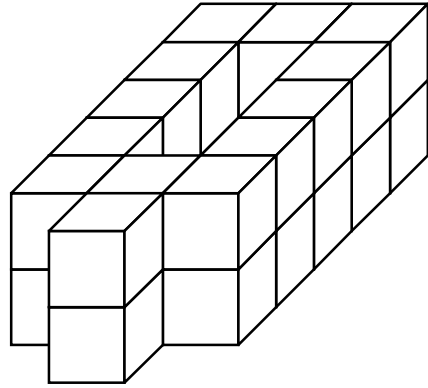
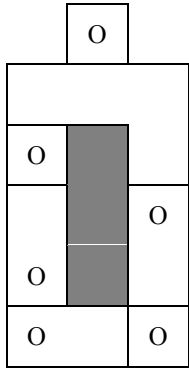
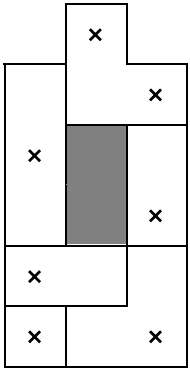

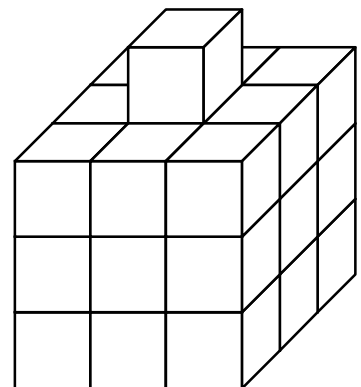
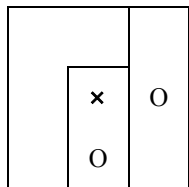
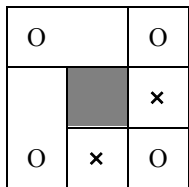
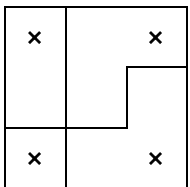
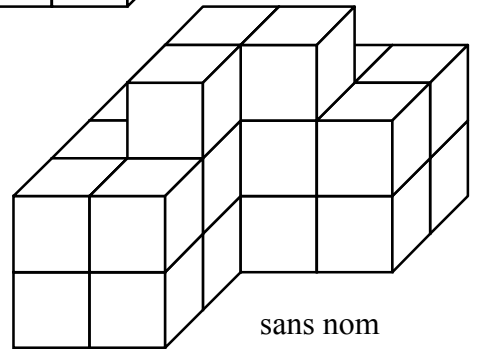
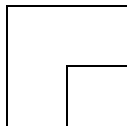
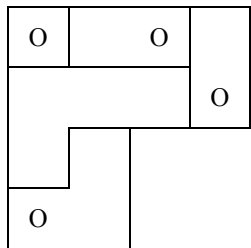
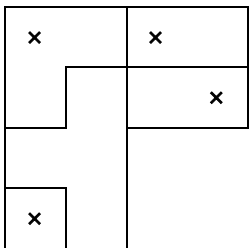
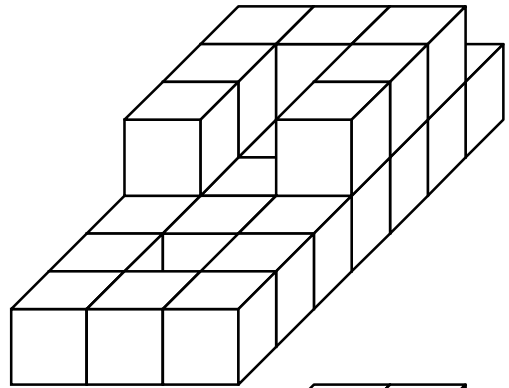
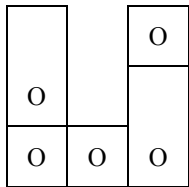
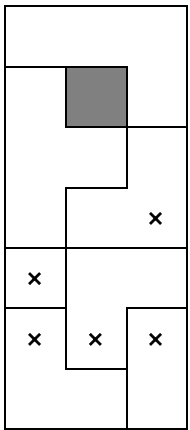
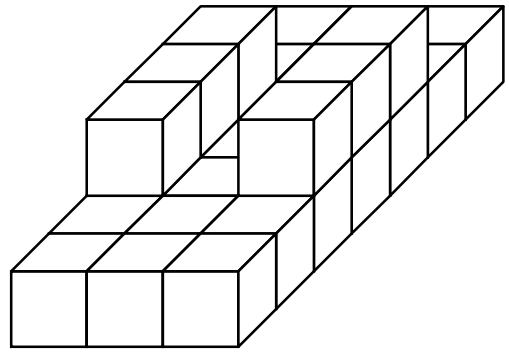
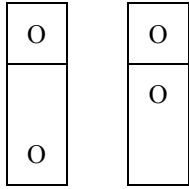
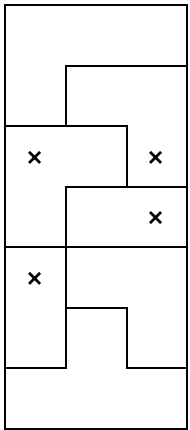

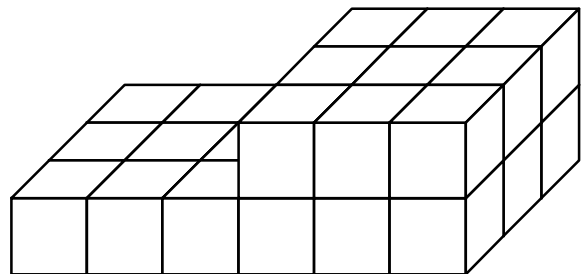
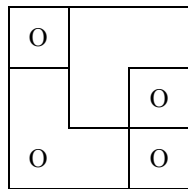
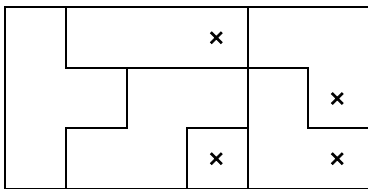
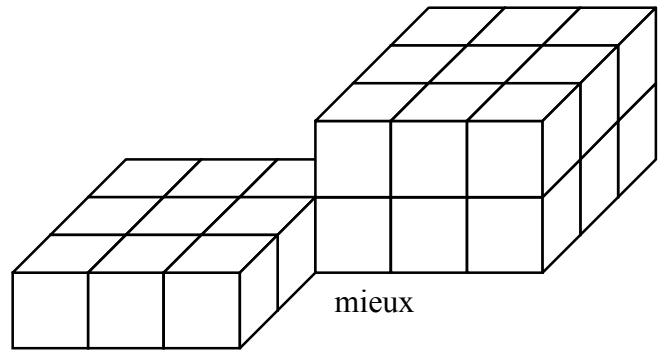
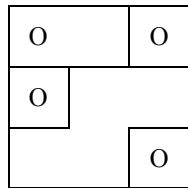
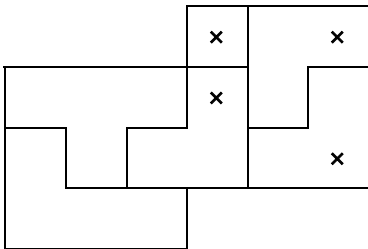
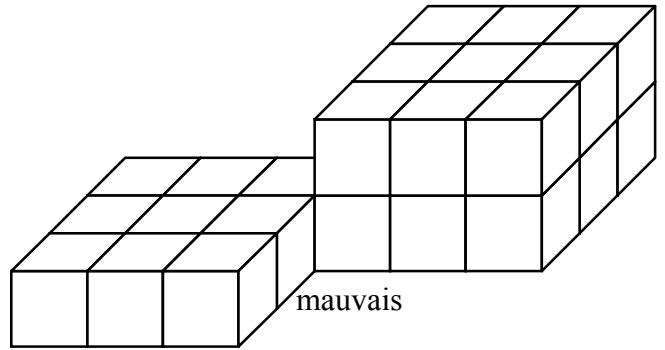
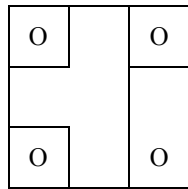
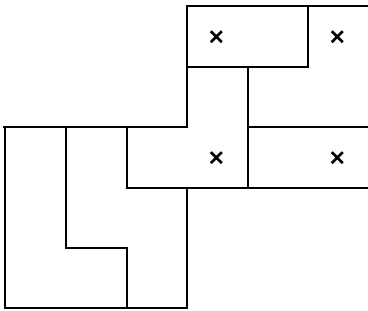
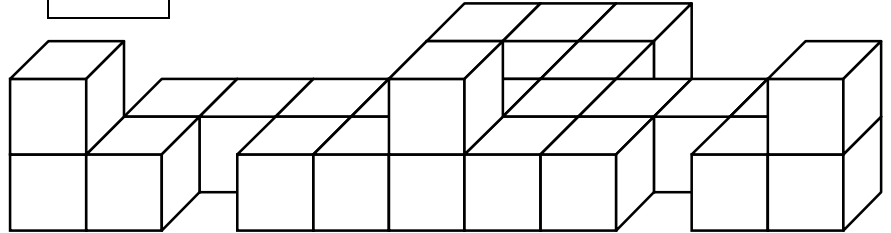
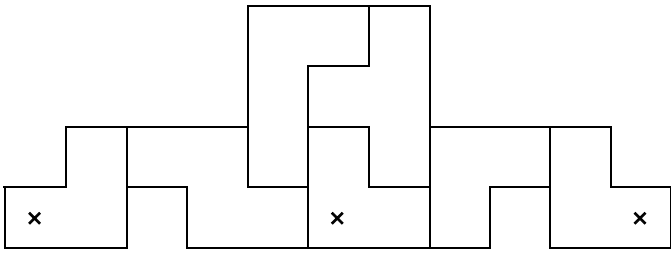

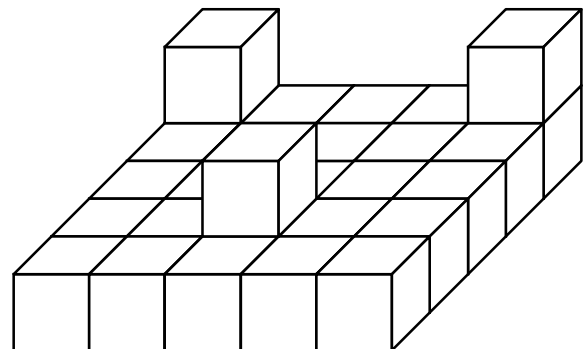
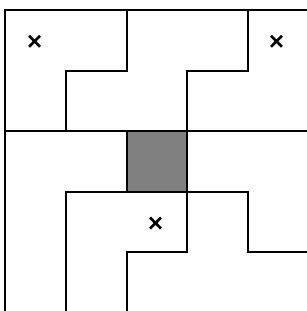
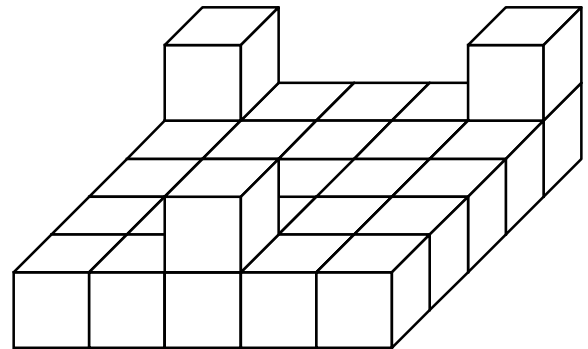
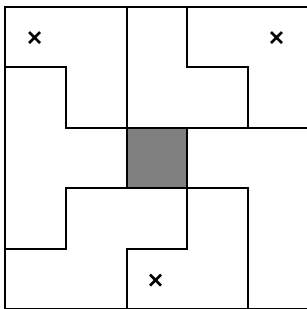
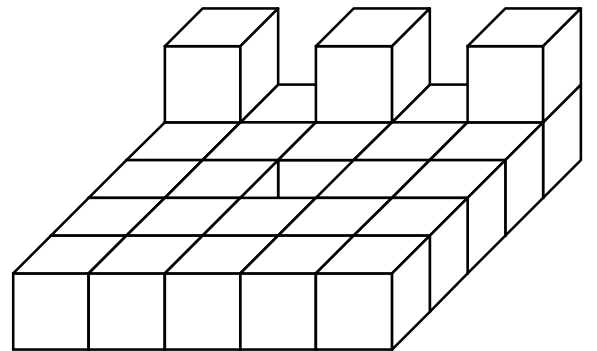
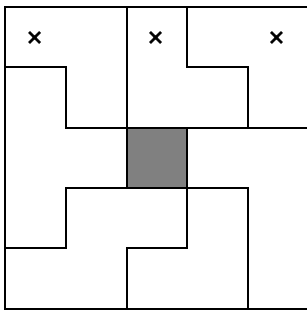
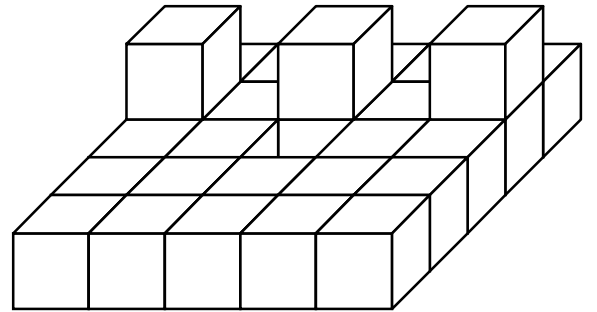
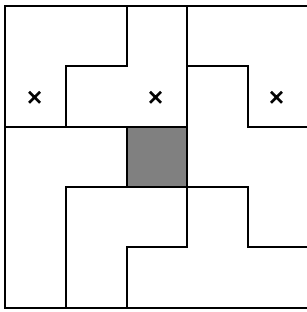

Des solides à reconstituer avec les sept pièces du cube Soma (5)

Le codage « O » signifie que la pièce se prolonge vers le bas, le codage « x » signifie que la pièce se prolonge vers le haut, le codage « ⊗ » signifie que la pièce se prolonge vers le haut et vers le bas.

La couche supérieure de l'assemblage de cubes formant le solide se trouve dans la partie droite du codage de la solution proposée par Claude Pagano (la couche inférieure se trouve dans la partie gauche). La solution codée et le dessin en perspective représentent parfois deux positions différentes du solide.

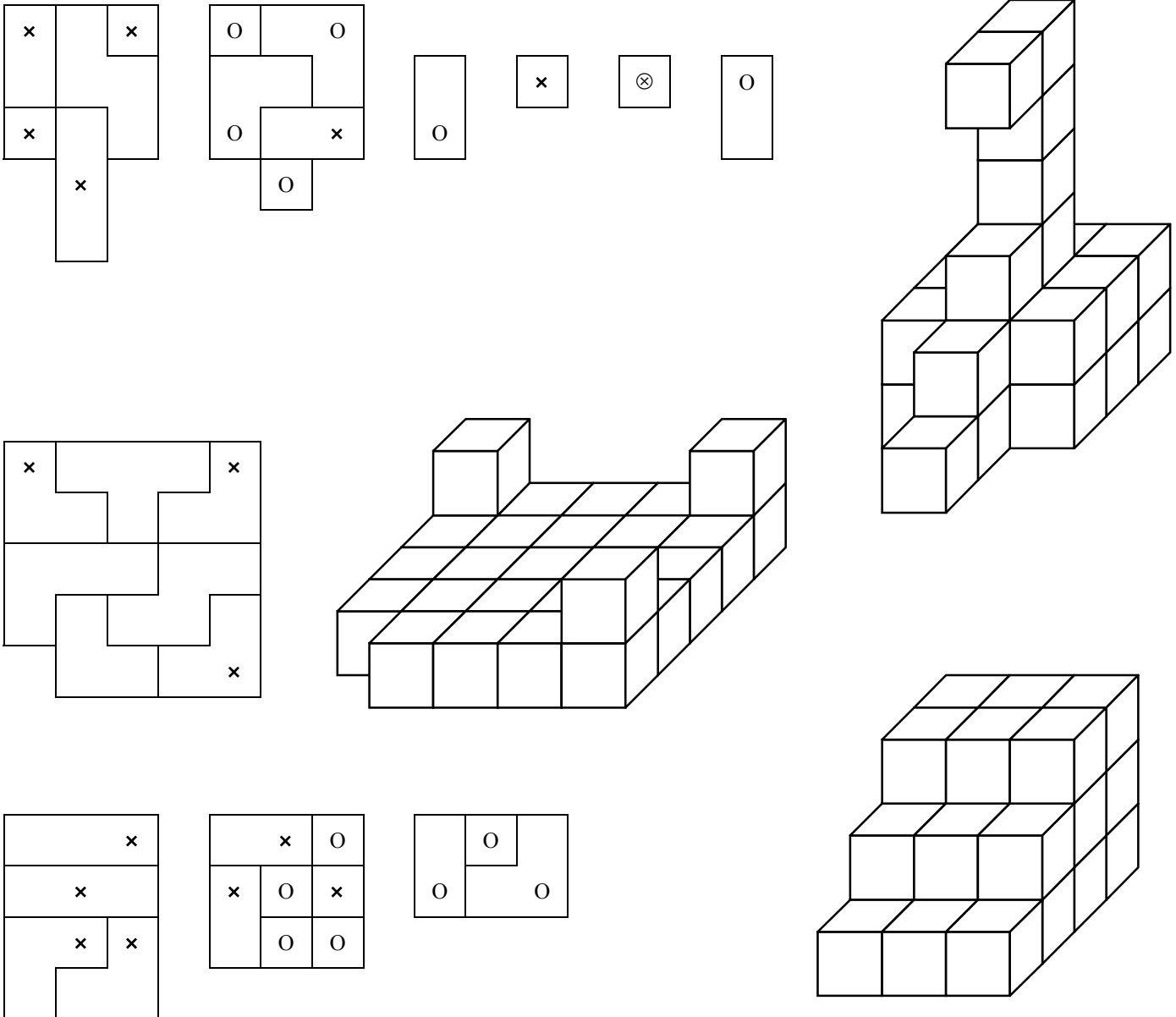

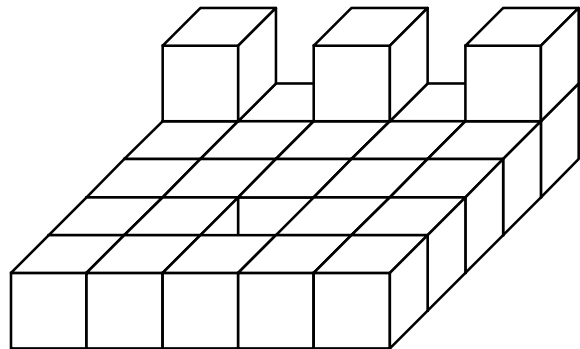
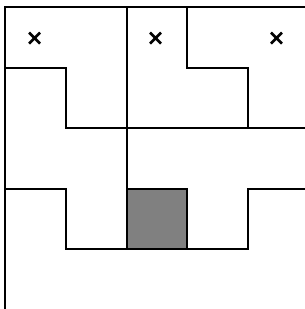
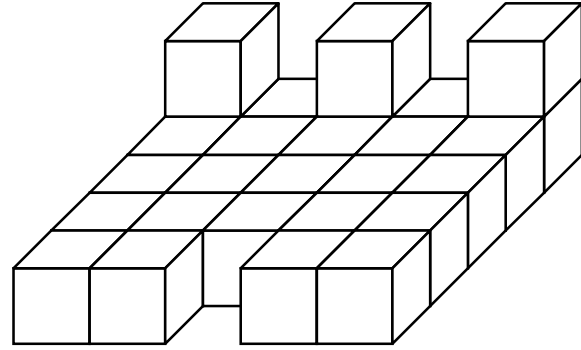
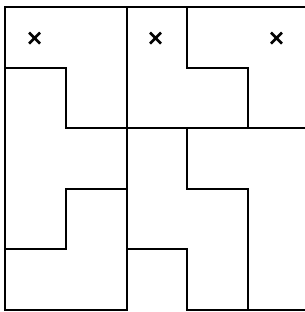
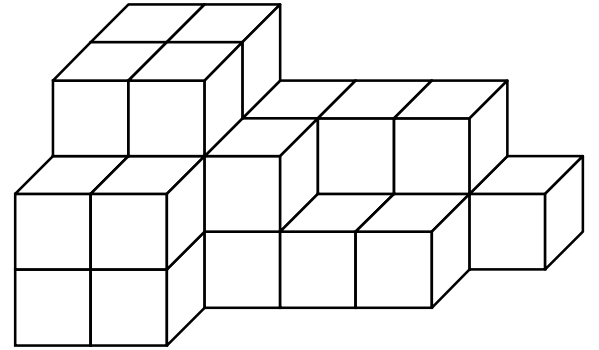
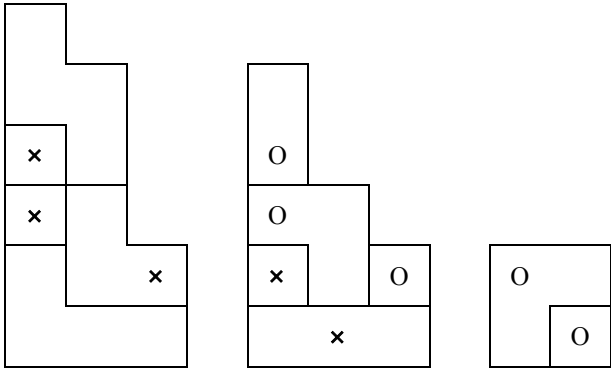
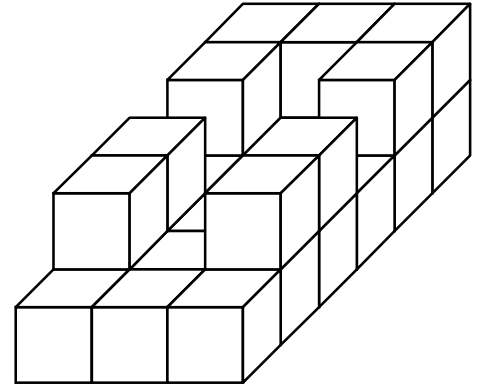
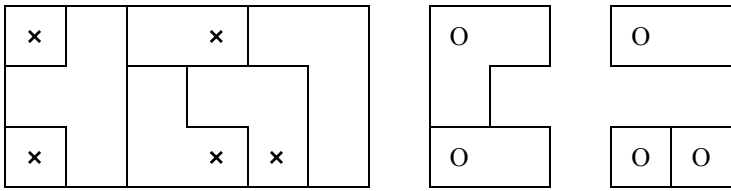

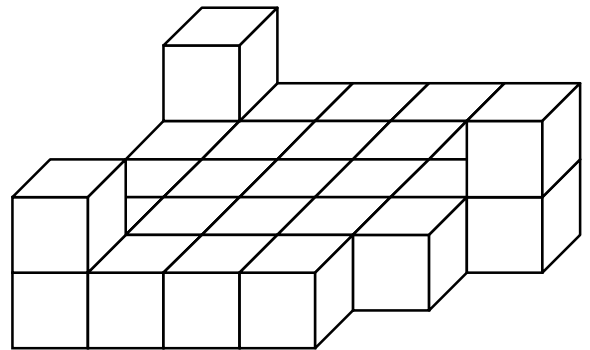
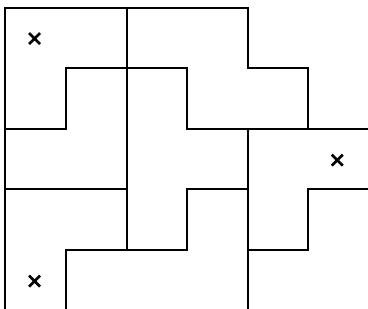
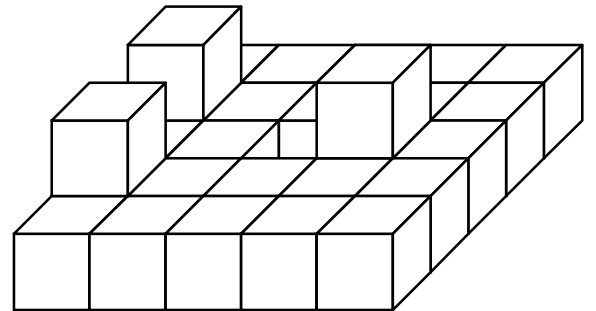
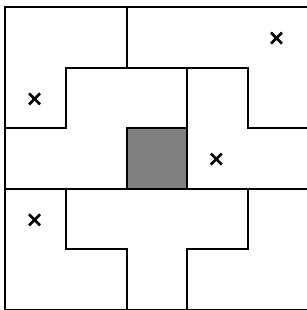
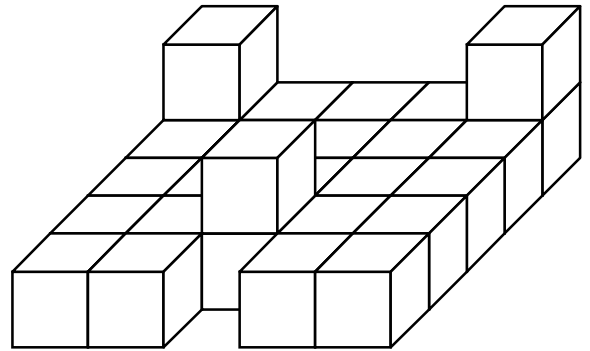
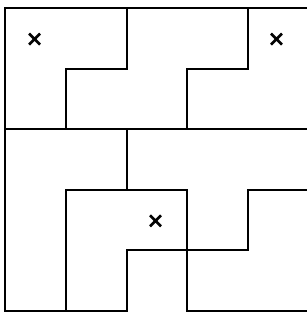
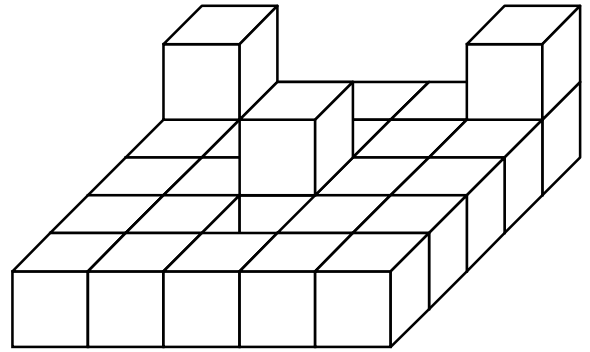
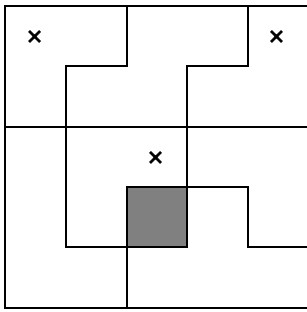

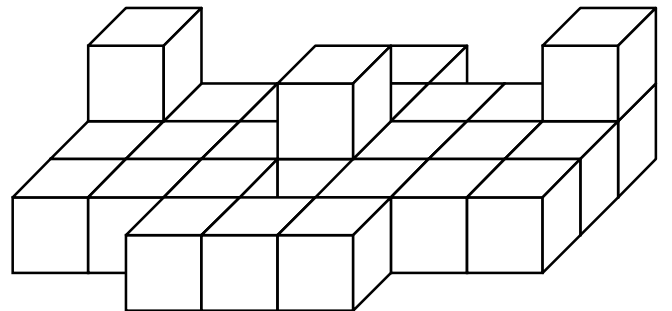
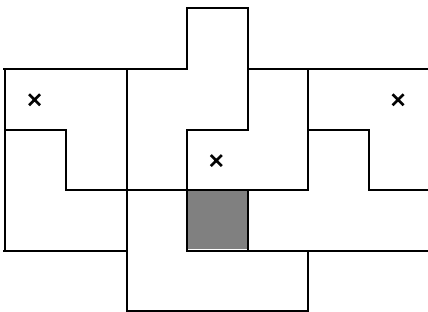
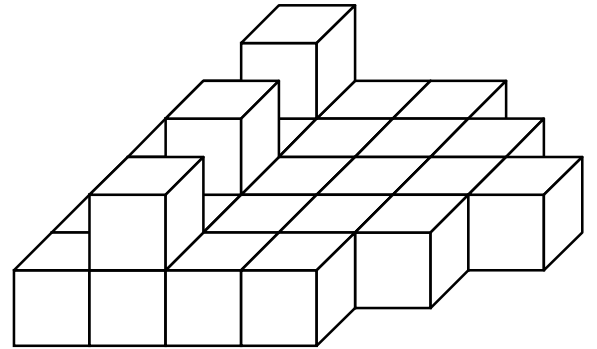
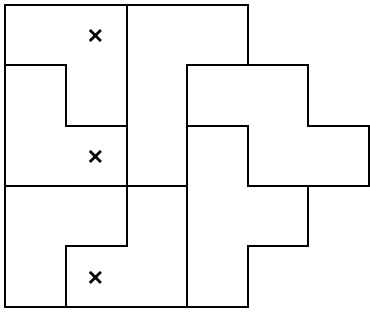
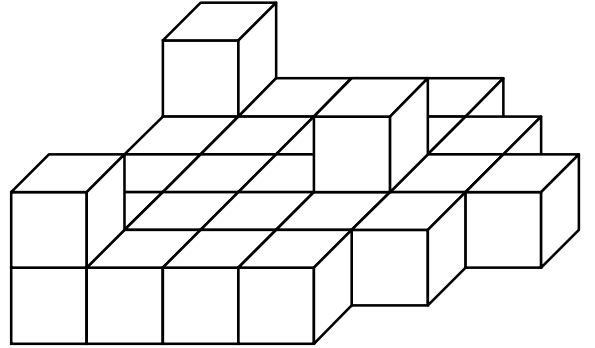
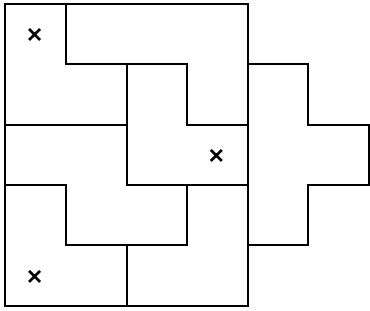
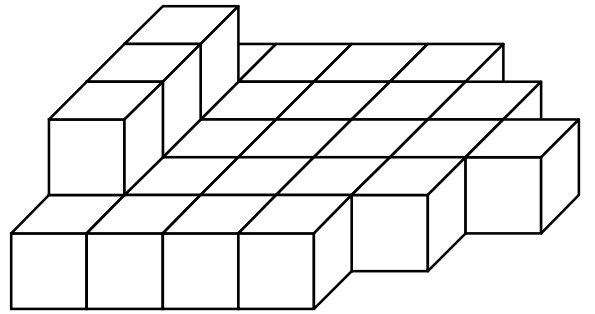
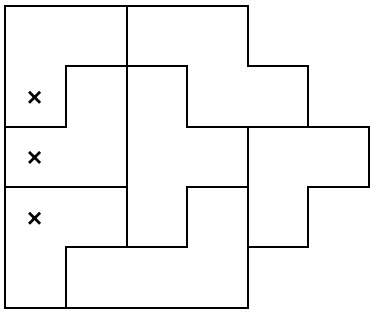

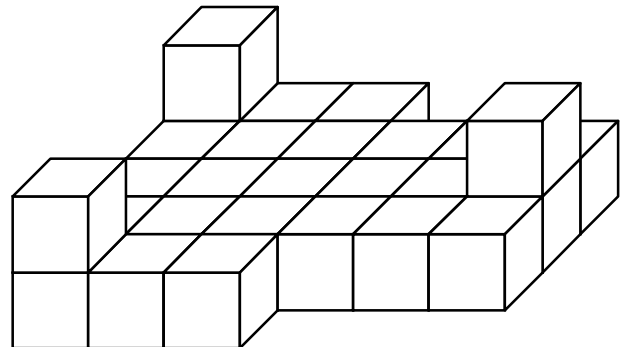
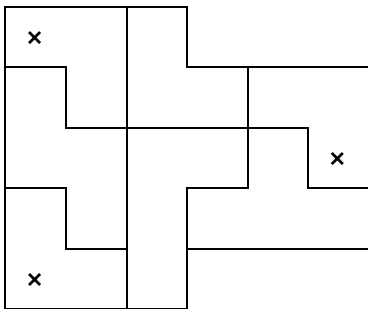
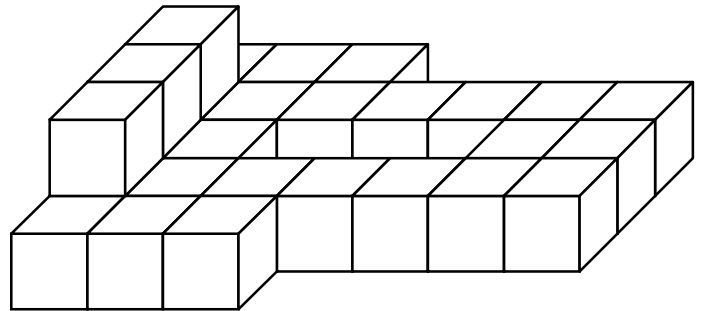
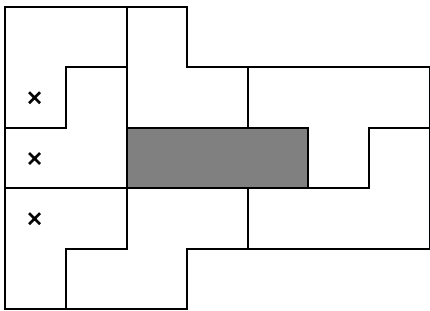
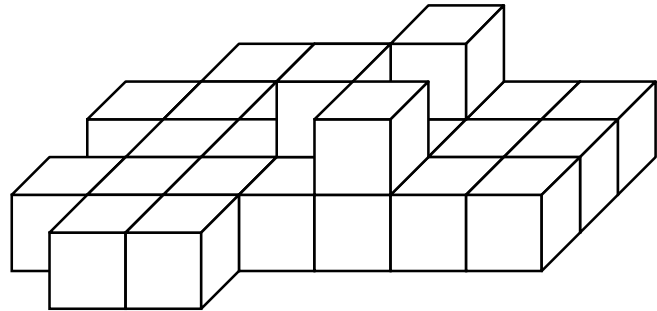
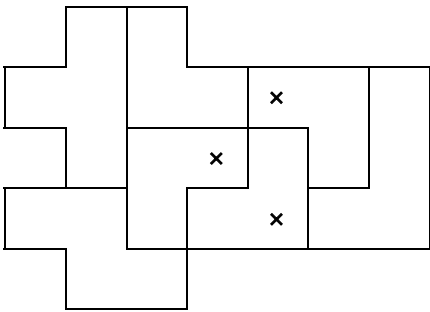
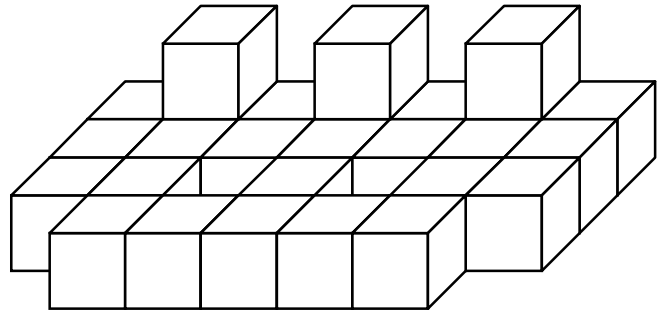
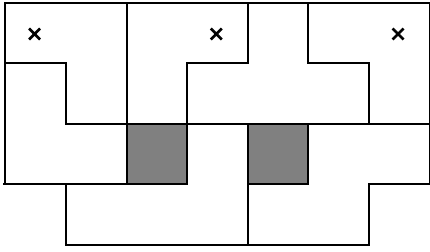
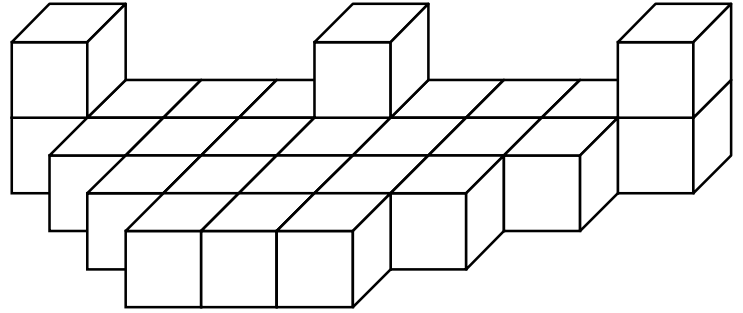
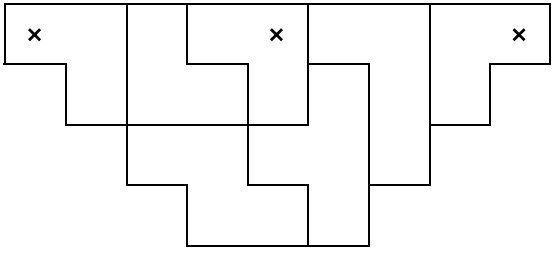

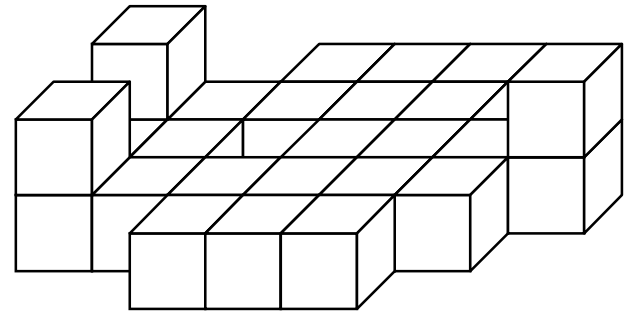
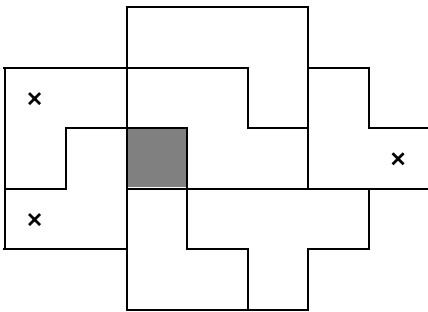
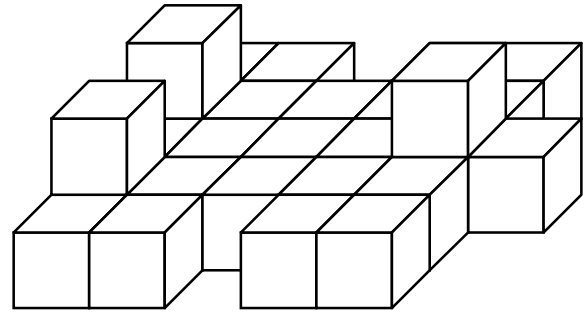
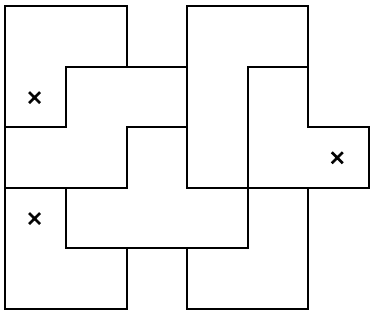
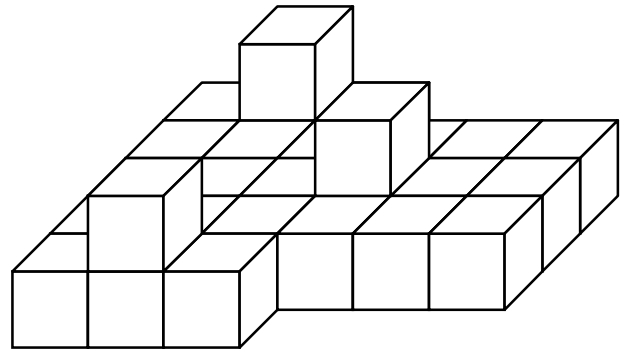
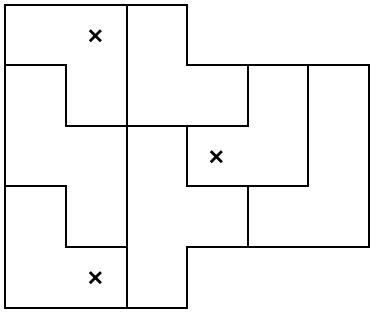
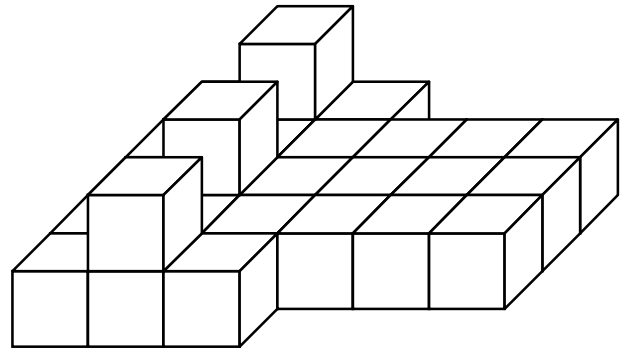
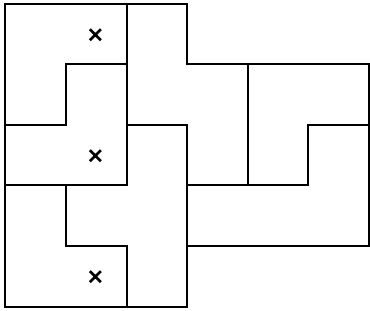

Des solides à reconstituer avec les sept pièces du cube Soma (6)

Le codage « O » signifie que la pièce se prolonge vers le bas, le codage « x » signifie que la pièce se prolonge vers le haut, le codage « ⊗ » signifie que la pièce se prolonge vers le haut et vers le bas.

La couche supérieure de l'assemblage de cubes formant le solide se trouve dans la partie droite du codage de la solution proposée par Claude Pagano (la couche inférieure se trouve dans la partie gauche). La solution codée et le dessin en perspective représentent parfois deux positions différentes du solide.

